



Operating Instructions

Fronius Ohmpilot



EN-US | Operating instructions



42,0426,0538,EA

012-25112024

Table of contents

General information	5
Safety	7
Explanation of Safety Instructions	7
General.....	7
EMC measures.....	8
Data backup.....	8
Copyright.....	8
General.....	9
How information is presented in the document.....	9
Intended use.....	9
Qualified personnel.....	9
System components required.....	10
Integrating the Fronius Smart Meter	10
Description of the device.....	10
System design	10
Information on the device	11
Operating controls and connections.....	13
Indications/controls on the device.....	13
Connection area.....	14
Selection of heater.....	16
1-phase heater.....	16
3-phase heater.....	16
Example of charging time calculation.....	16
Installation and Startup	17
Choosing a location and installation position.....	19
Choosing location - general remarks	19
Choosing a location.....	19
Installation position.....	20
Wall mounting.....	21
Safety	21
Selecting dowels and screws	21
Mounting the Ohmpilot on the wall.....	21
Installation.....	23
Stripping lengths.....	23
Electrical connection.....	23
1-phase heating element up to 3 kW	25
Application example 1.....	25
3-phase heating element 900 W up to 9 kW	26
Application example 2.....	26
1-phase heating element up to 3 kW with heat pump control	27
Application example 3.....	27
Settings in menu area.....	28
1-phase heating element up to 3 kW and external source	30
Application example 4.....	30
Settings in menu area.....	31
Two heating elements - 3-phase and 1-phase	32
Application example 5.....	32
Settings in menu area.....	33
Two 3-phase heating elements up to 9 kW.....	34
Application example 6.....	34
Settings in menu area.....	35
1-phase heating element up to 3 kW / 3-phase heating element and circulation pump.....	36
Application example 7.....	36
Settings in menu area.....	37
Establishing the data connection	39
Possible communication channels	39

Pairing the inverter with the Ohmpilot.....	39
Establishing a connection via Modbus RTU.....	39
Establishing a connection via LAN.....	40
Establishing a connection via WLAN.....	41
Boost Mode.....	44
Boost mode.....	44
Settings in menu area.....	44
User interface.....	45
Status display.....	45
Optional settings.....	46
HEATER 1 manual settings.....	46
Activating Legionella prevention.....	47
Adapting the day curve.....	47
Temperature limitation.....	48

Appendix **49**

Status codes.....	51
Status codes.....	51
Technical data.....	54
Fronius Ohmpilot technical data.....	54
Tests/specifications.....	55
Tests/specifications.....	55
Terms and conditions of warranty and disposal.....	56
Fronius manufacturer's warranty.....	56
Disposal.....	56
Applicable standards and directives.....	56

General information

Safety

Explanation of Safety Instructions

DANGER!

Indicates an immediate danger.

- ▶ Death or serious injury may result if appropriate precautions are not taken.
-

WARNING!

Indicates a possibly dangerous situation.

- ▶ Death or serious injury may result if appropriate precautions are not taken.
-

CAUTION!

Indicates a situation where damage or injury could occur.

- ▶ Minor injury or damage to property may result if appropriate precautions are not taken.
-

NOTE!

Indicates the possibility of flawed results and damage to the equipment.

General

The device has been manufactured in line with the state of the art and taking into account recognized safety regulations. If used incorrectly or misused, there is a risk of:

- Serious or fatal injury to the operator or third parties
 - Damage to the device and other material assets belonging to the operating company
-

All personnel involved in commissioning, maintenance, and servicing of the device must:

- Be suitably qualified
 - Have knowledge of and experience in dealing with electrical installations
 - Have fully read and precisely followed these operating instructions
-

In addition to the operating instructions, all applicable local regulations regarding accident prevention and environmental protection must also be followed.

All safety and danger notices on the device:

- Must be kept in a legible state
 - Must not be damaged
 - Must not be removed
 - Must not be covered, have anything stuck on them, or painted over
-

Only operate the device when all safety devices are fully functional. If the safety devices are not fully functional, there is a danger of:

- Serious or fatal injury to the operator or third parties
 - Damage to the device and other material assets belonging to the operating company
-

Any safety devices that are not fully functional must be repaired by an authorized specialist before the device is switched on.

Never bypass or disable safety devices.

For the location of the safety and danger notices on the device, refer to the chapter headed "Information on the device" in the operating instructions for your device.

Any equipment malfunctions which impair safety must be remedied before the device is turned on.

EMC measures

In certain cases, even though a device complies with the standard limit values for emissions, it may affect the application area for which it was designed (e.g., when there is equipment that is susceptible to interference at the same location or if the site where the device is installed is close to either radio or television receivers). If this is the case, the operator is obliged to take action to rectify the situation.

Data backup

With regard to data security, the user is responsible for:

- backing up any changes made to the factory settings
- saving and storing personal settings

Copyright

Copyright of these operating instructions remains with the manufacturer.

Text and illustrations were accurate at the time of printing, subject to change. We are grateful for suggestions for improvement and information on any discrepancies in the operating instructions.

General

How information is presented in the document

The conventions regarding how information is presented in the document, which are set out below, have been defined in order to increase the readability and comprehensibility of the document.

Application notes

IMPORTANT! Indicates application notes and other useful information. It does not indicate a harmful or dangerous situation.

Software

Software functions and elements of a graphical user interface (e.g., buttons, menu items) are highlighted in the text with this **mark up**.

Example: Click **Save**.

Instructions for action

- 1 Action steps are displayed with consecutive numbering.
 - ✓ *This symbol indicates the result of the action step or the entire instruction.*

Intended use

The Fronius Ohmpilot is an addition to the Fronius product portfolio in the field of energy management. The device controls the heating of hot water using surplus energy from a photovoltaic system. Any other use is considered improper.

Qualified personnel

The information contained in these operating instructions is intended only for qualified personnel. An electric shock can be fatal. Do not carry out any actions other than those described in the documentation. This also applies to qualified personnel.

All cables must be secured, undamaged, insulated, and adequately dimensioned. Loose connections, damaged or under-dimensioned cables must be repaired immediately by an authorized specialist company.

Maintenance and repair work must only be carried out by an authorized specialist company.

It is impossible to guarantee that third-party parts are designed and manufactured to meet the demands made on them, or that they satisfy safety requirements. Only use original spare parts.

Do not carry out any alterations, installations, or modifications to the device without first obtaining the manufacturer's permission.

Replace any damaged components or have them replaced immediately.

System components required

- GEN24 inverter
 - Fronius Primo / Symo GEN24
 - Fronius SnapINverter
 - Fronius Symo / Galvo / Eco or Primo (from Fronius Datamanager 2.0 software version 3.8.1-x onwards) or Fronius Symo Hybrid (from Fronius Hybridmanager software version V1.8.1.x onwards)
 - Fronius Smart Meter
 - Fronius Ohmpilot
 - Resistive load (e.g., boiler with heating element)
-

Integrating the Fronius Smart Meter

To operate the Ohmpilot, a Fronius Smart Meter is required to measure the surplus energy. On the user interface of the inverter, it is necessary to set whether the Fronius Smart Meter is installed at the feed-in point or in the consumption branch.

Description of the device

The Ohmpilot uses pulse width modulation to regulate the surplus power from the photovoltaic system for one phase. With one phase, it is possible to control a heating element with a continuously variable output of up to 3 kW, for example. The Ohmpilot has two additional outputs for switching further phases. This means that heating elements with an output of 300 W to 9 kW can be controlled.

For a heating element with 9 kW output, the surplus power of 0-3 kW is controlled in phase 1. If more power is available, the Ohmpilot switches to phase 2. Phase 1 can therefore be continuously adjusted between 3 and 6 kW. If the available power is > 6 kW, the Ohmpilot adds phase 3. Phase 1 is again continuously adjusted between 6 and 9 kW

Power range	Phase 1	Phase 2	Phase 3
0-3 kW	0-3 kW continuously variable	-	-
3-6 kW	0-3 kW continuously variable	3 kW fixed	-
6-9 kW	0-3 kW continuously variable	3 kW fixed	3 kW fixed

Other resistive loads such as infrared heaters and towel dryers can also be controlled.

System design **CAUTION!****Danger from connecting an electronic thermostat.**

This would destroy the Ohmpilot or the connected load.

- Use mechanical temperature switches.
-

 **CAUTION!****Danger due to connection of an incorrect load (e.g., fan heater).**

This may result in destruction of the load.

- Connect only purely resistive loads.
-

NOTE!

Phase control

The sum of all phases forms the basis for Ohmpilot control. The Ohmpilot is not suitable for phase-accurate billing.

NOTE!

Ohmpilot and Fronius Datamanager 2.0 / Fronius Hybridmanager

Only one Ohmpilot can be connected per Fronius Datamanager 2.0 / Fronius Hybridmanager.

NOTE!

Ohmpilot and dynamic power reduction

From software version 3.13.1-x of the Fronius Datamanager or 1.11.1-x of the Fronius Hybridmanager, the Ohmpilot can be used together with dynamic power reduction from 0-100%.

NOTE!

Use of other generation sources

Other generation sources can also be used in conjunction with the Fronius Datamanager Box 2.0, e.g., CHP, third-party inverters, etc. Generated power and consumption data cannot be acquired for other generation sources, so these figures cannot be displayed in Fronius Solar.web.

NOTE!

Backup power

Due to the high heat output, the Ohmpilot cannot be operated in backup power situations.

- ▶ Install the Ohmpilot outside the backup power circuit.
-

NOTE!

Calcification of the connected heating element

Calcification can occur with hard water, especially if the minimum temperature is set above 60 °C. An annual inspection of the heating element is recommended.

- ▶ Remove the heating element from the tank and remove the limescale;
 - ▶ do not scratch the surface of the heating element while doing so.
-

Information on the device

Safety symbols and warnings are located on the left-hand side of the Ohmpilot. These warning notices and safety symbols must not be removed or painted over. They warn against incorrect operation, as this may result in serious injury and property damage.

Fronius Ohmpilot 9.0-3	
A-4500 Weiss www.fronius.com	
Art.Nr.: 14240.160	
Ser.Nr.:	
U	1-230V/3-400V/50 Hz
P _{Load(max)}	9000 W
IP 54	16A
I _{In}	1x16A/3x16A
I _{Analog Out}	13A
I _{Relay}	13A
Leistungssteller / Power Controller / Régulateurs de puissance	

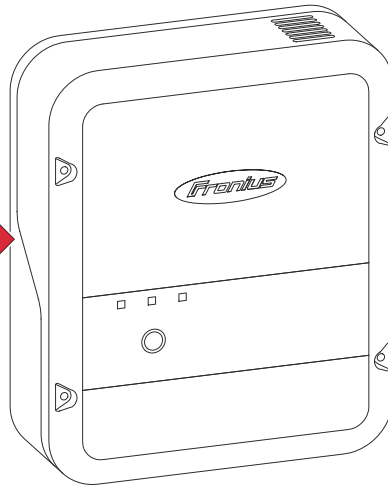

WARNUNG! Ohmpilot darf nur über Überspannungsschutzschaltung angeschlossen werden.
WARNUNG! Ein elektrischer Schlag kann tödlich sein. Vor dem Öffnen des Gehäuses dafür sorgen, dass Ein- und Ausgangsseite spannungsfrei sind.
 EMC emission Class B

Safety symbols:



Danger of serious injury and property damage due to incorrect operation



Do not use the functions described here until you have fully read and understood the following documents:

- These operating instructions
- All system component operating instructions, especially the safety rules



Dangerous electrical voltage



Wait until the capacitors have discharged before opening the device.



Hot surface

Warning notice text:

WARNING!

An electric shock can be fatal. Before opening the device, ensure that the input and output sides are de-energized. Allow the capacitors to discharge (wait 15 seconds).

WARNING!

The device must not be covered and nothing must be hung over the device or the cables.

Operating controls and connections

Indications/ controls on the device



Function key

Press 1x

1x WPS
2x ACCESS POINT
3x BOOST MODE

WPS (Wi-Fi Protected Setup) opens for 2 minutes or until successful pairing with the router. Pressing the WPS button on the router sends the WLAN password to the Ohmpilot.

Press 2x

WLAN access point is activated for 30 minutes so that settings can be implemented on the Ohmpilot via the Fronius Solar.start app.

Press 3x

Boost mode - dimmer level is activated at 100% for 4 hours, switching takes place through phases 2 and 3. This may result in electricity being sourced from the grid.

Press again

Ohmpilot is returned to the standard operating mode; boost mode, access point, or WPS are deactivated.

Press for 7
seconds

Ohmpilot restarts



Heater indication

Unlit

No power supply to the Ohmpilot.

Flashing green
(permanently)



The faster the flashing frequency, the greater the heat output. The LED flashes slowly at 0 W heat output and quickly at full output.

Flashing green
(twice)

The heating element output is being measured. The Ohmpilot recognizes whether a 1-phase or 3-phase heating element is connected.

Lights up
green

Minimum temperature undershot or Legionella prevention system active (full heat output).

	LAN / WLAN connection indicator	Unlit	No connection
		Flashing blue (once)	WPS (Wi-Fi Protected Setup) open
		Flashing blue (twice)	WLAN access point open
		Lights steady blue	Connection with network
	Error indication	Unlit	No error
		Flashing red (once)	No connection to the inverter
		Flashing red (twice)	Temperature measurement faulty
		Flashing red (three times)	Heating element faulty
		Flashing red (four times)	Ohmpilot faulty
		Flashing red (five times)	Minimum temperature not reached
		A detailed description of the error is provided in Fronius Solar.web.	

Connection area

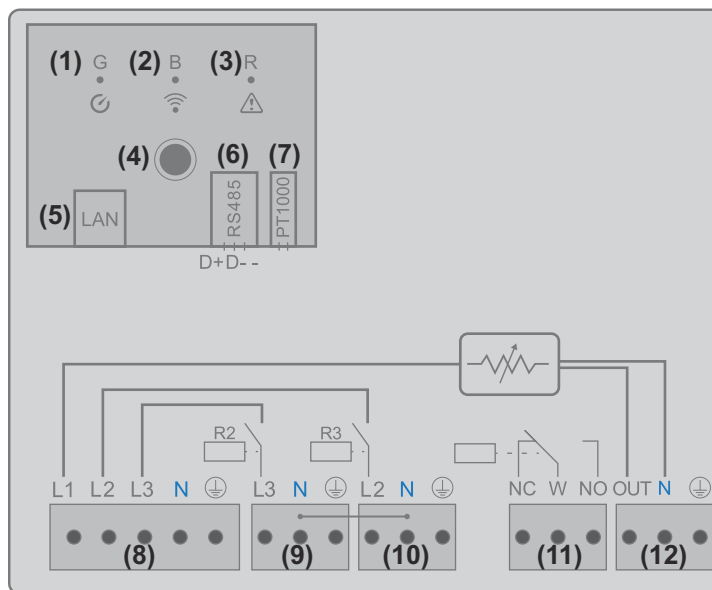

- | | |
|-----|---|
| (1) | Green LED |
| (2) | Blue LED |
| (3) | Red LED |
| (4) | Function key |
| (5) | Ethernet RJ45
Cable at least CAT5, shielded |

-
- (6) **Modbus RTU (default address 40)**
Spring balancer 0.2-1.5 mm², cable length max. 300 m, shielded and twisted
-
- (7) **Temperature sensor terminal**
Cable sensor PT1000, spring balancer 0.2-1.5 mm²
-
- (8) **Input - grid supply**
1x 230 V or 3x 230 V, spring balancer 1.5-2.5 mm²
-
- (9) **Output - L3 heating element**
Spring balancer 1.5-2.5 mm²
-
- (10) **Output - L2 heating element**
Spring balancer 1.5-2.5 mm²
-
- (11) **Multifunctional relay output**
Variable max. 13 A resistive load, spring balancer 1.5-2.5 mm²

 **WARNING!**

Danger due to wires coming loose

Loose wires can come into contact with live parts and cause an electric shock.

- ▶ When connecting signal cables, tie the individual wires together with a cable tie immediately before the terminal.

-
- (12) **Output - heating element / dimming level L1**
Continuously variable up to 3 kW
Spring balancer 1.5-2.5 mm²
-

Selection of heater

1-phase heater

- Controlled in a continuously variable manner from 0.3 to 3 kW
- Resistive load (no electronic temperature limiters, fans, etc.)

3-phase heater

- Controlled in a continuously variable manner from 0.3 to 9 kW.
- Equal load distribution on all 3 phases (e.g., 3x 3 kW).
- If a mechanical temperature switch is being used, it must switch all 3 phases simultaneously.
- Purely resistive load (no electronic temperature limiters, fans, etc.)
- Neutral conductor must be connected

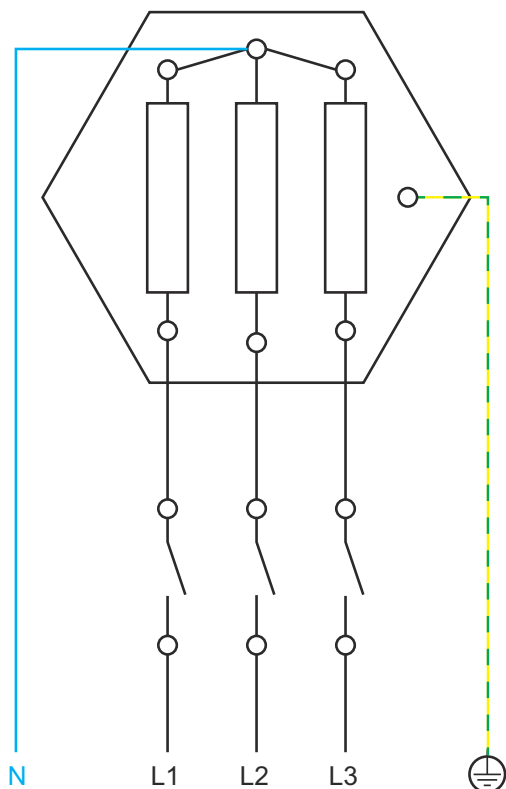

Temperature limitation

A mechanical temperature switch simplifies commissioning and use. If no mechanical temperature switch is available, a temperature sensor can also be connected to the Ohmpilot. This limits the maximum temperature (see chapter "[Temperature limitation](#)" on page).

Example of charging time calculation

500 l boiler, heater is installed at the very bottom of the boiler, temperature spread 45 - 60 °C = 15 °C
4.5 kW heater

Possible storage energy = 500 l (storage capacity) x 1.16 Wh (energy requirement per liter) x 15 °C (temperature spread) = 8.7 kWh. When the heater is fully activated (4.5 kW), it takes approx. 2 hours to heat the tank.

For optimal use of the excess power and rapid reheating of the hot water, adjust the power of the heater to the power of the photovoltaic system, e.g., 5 kWp system power => 4.5 kW heater

Installation and Startup

Choosing a location and installation position

Choosing location - general remarks

Please note the following criteria when choosing a location for the Ohmpilot:

Install only on a solid surface.

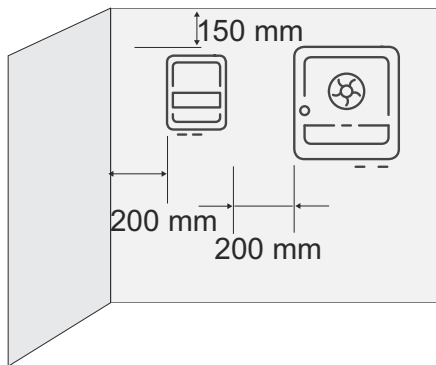

Max. ambient temperatures:
0 °C / +40 °C

Relative humidity:
0-99%

The airflow within the Ohmpilot is from the bottom to the top.

If the Ohmpilot is installed in an enclosed space, forced-air ventilation must be provided to ensure adequate heat dissipation.

NOTE!

Cable length

The maximum cable length from the output of the Ohmpilot to the load (heating element) must not exceed 5 m.

Choosing a location



The Ohmpilot is suitable for indoor installation. The housing satisfies protection class IP 54 and is protected against splashing water on all sides.



In order to minimize heating up of the Ohmpilot, do not expose it to direct sunlight. Install the Ohmpilot in a protected position. The Ohmpilot must only be installed and operated at an ambient temperature of 0-40 °C.

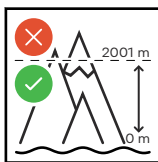

IMPORTANT! The Ohmpilot must not be installed or used at altitudes above 2,000 m.



Do not install the Ohmpilot:

- In areas where ammonia, corrosive vapors, acids, or salts are present (e.g., fertilizer stores, ventilation openings from cattle sheds, chemical plants, tanneries, etc.)



Do not install the Ohmpilot in:

- Places where there is an increased risk of damage from farm animals (horses, cattle, sheep, pigs, etc.)
- Stables or adjoining areas
- Storage areas for hay, straw, chaff, animal feed, fertilizers, etc.

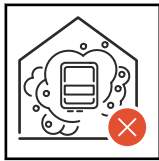

Do not install the Ohmpilot in rooms or environments where there is a lot of dust. All Ohmpilot units are designed to be dust-tight. However, in areas with a heavy build-up of dust, the thermal efficiency may still be impaired by dust forming on the cooling surfaces. Regular cleaning is necessary in such situations.



Do not install the Ohmpilot in:

- Greenhouses
- Storage or processing areas for fruit, vegetables, or viticulture products
- Areas used in the preparation of grain, green fodder, or animal feeds

Installation position



The Ohmpilot must be installed level, with the connections facing downwards, on a vertical wall. All inclined and horizontal installation positions are prohibited.

Wall mounting

Safety

⚠ WARNING!

Danger due to residual voltage from capacitors.

An electric shock can be fatal!

- ▶ Before opening the device, wait for the capacitors to discharge (15 seconds).

⚠ WARNING!

Risk of burns from the heat sink when open.

This can result in personal injury.

- ▶ Wear suitable protective equipment.
- ▶ Allow heat sink to cool.
- ▶ Do not touch the hot heat sink.

IMPORTANT! The IP 54 protection class only applies if the cover is firmly screwed to the back.

Selecting dowels and screws

IMPORTANT! Depending on the surface, different mounting materials may be required to mount the Ohmpilot. Fasteners and mounting materials are not included in the scope of supply. The installer is responsible for selecting the proper mounting materials. The system must be set up on a level, stable surface.

Fronius recommends using steel screws with a diameter of 4 - 6 mm for mounting the Ohmpilot in masonry.

Mounting the Ohmpilot on the wall

NOTE!

Risk of dirt and moisture on the connections or electronic components

This may result in damage to the Ohmpilot.

- ▶ When drilling, ensure that terminals and electronic components in the connection area do not become dirty or wet.

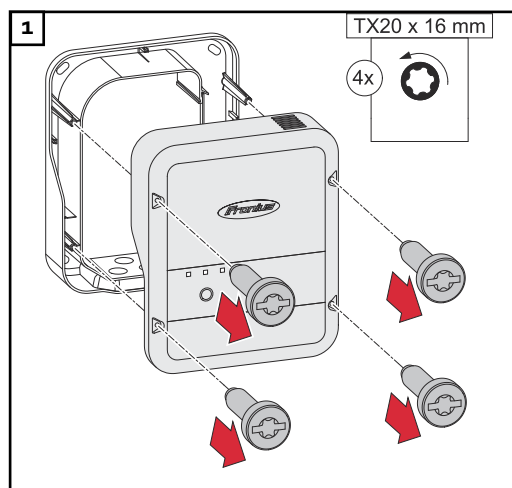

Undo the 4 screws and remove the housing cover.

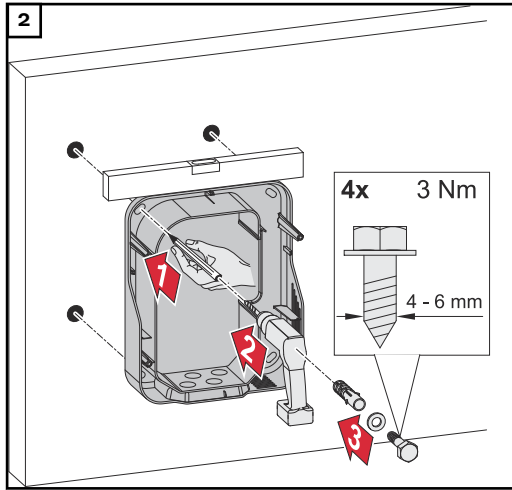

Mark drill holes, drill and insert wall plugs

3 Attach the Ohmpilot to the wall with 4 screws

Installation

Stripping lengths

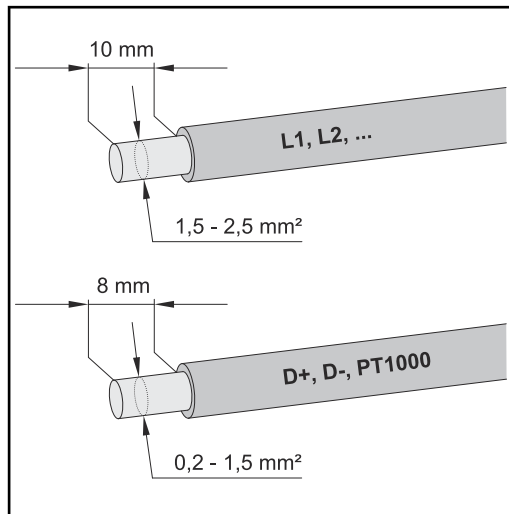

Stripping lengths of terminals for power stage set (L1, L2, etc.) and terminals for data communication area (D+, D-, PT1000)

Electrical connection

IMPORTANT! The electrical connection may only be established by an expert.

WARNING!

Danger due to insufficient ground conductor connection.

This can result in severe personal injury and damage to property.

- Install and connect the ground conductor connection in accordance with national specifications

NOTE!

Neutral conductor connection

If the neutral conductor is not connected, damage to the device will result.

- Start up and operate the Ohmpilot only with an active neutral conductor connection.

NOTE!

Overvoltage from grid

Overvoltage can damage the device

- Equip the Ohmpilot with a type B16 A automatic circuit breaker and a residual current circuit breaker.

NOTE!

Cable length

The maximum cable length from the output of the Ohmpilot to the load (heating element) must not exceed 5 meters due to electromagnetic compatibility

NOTE!

Load connection

- ▶ Only purely ohmic loads may be connected.
 - ▶ When connecting a heating element, check the grounding of the boiler/ buffer and the heating system.
 - ▶ Observe the maximum permissible inlet water and hot water temperature when setting the temperature on the heating element.
-

1-phase heating element up to 3 kW

Application example 1

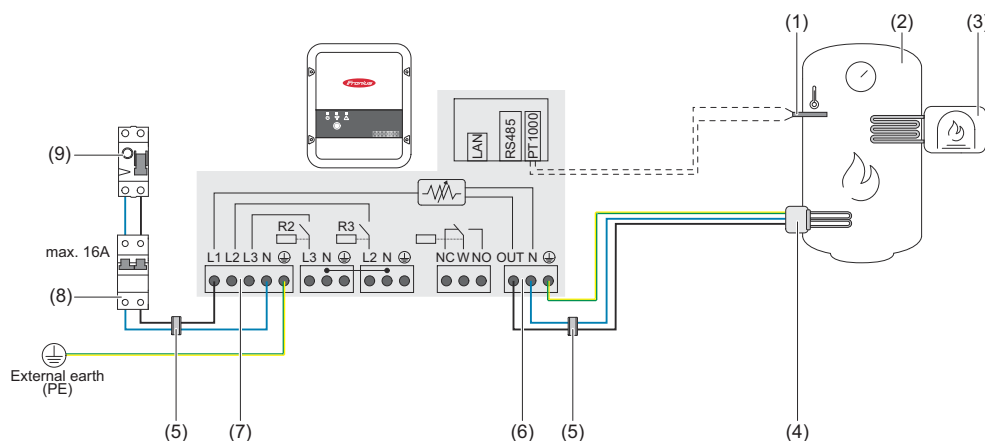

IMPORTANT! A neutral conductor must be connected to each heating element.

- (1) **Temperature sensor** PT1000
- (2) **Hot water boiler**
- (3) **External source** (e.g., gas boiler)
- (4) **Heating element** (max. 3 kW)
- (5) **Ferrite rings** (included in the scope of supply)
- (6) **Output up to 3 kW** (adjustable), max. 13 A ohmic load, spring-type terminal 1.5 - 2.5 mm²
- (7) **Input - supply line from grid** 1x 230 V, spring-type terminal 1.5 - 2.5 mm²
- (8) **Automatic circuit breaker max. B16A**
- (9) **Residual current circuit breaker**

IMPORTANT! Plug & Play - In this application, no further settings are required after successful connection to the inverter.

The Fronius Smart Meter records the current power at the feed-in point and transmits the data to the inverter. The inverter adjusts the available surplus energy to zero by activating the Ohmpilot (specifically by continuously controlling the heating element connected to the Ohmpilot). The surplus energy is consumed by the heating element (steplessly variable).

If no temperature sensor is installed, a third-party source (e.g., gas boiler) must ensure the minimum temperature.

As an alternative, the Ohmpilot can ensure the minimum temperature. To do this, a temperature sensor must be connected so that the Ohmpilot can measure the temperature. This can result in electricity being drawn from the grid.

The maximum temperature must be set on the heating element thermostat. If the heating element does not have a thermostat, the Ohmpilot can also carry out this task as an alternative (see chapter [Optional settings](#) on page 46).

3-phase heating element 900 W up to 9 kW

Application example 2

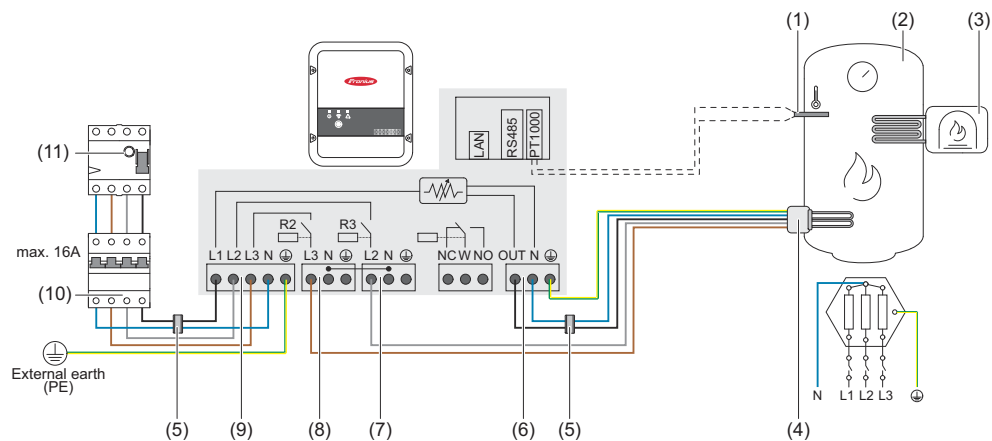

IMPORTANT! A neutral conductor must be connected to each heating element.

- (1) **Temperature sensor** PT1000
- (2) **Hot water boiler**
- (3) **External source** (e.g., gas boiler)
- (4) **Heating element** (max. 9 kW)
- (5) **Ferrite rings** (included in the scope of supply)
- (6) **Output up to 3 kW** (adjustable), max. 13 A, ohmic load, spring-type terminal 1.5 - 2.5 mm²
- (7) **Output - heating element L2**
- (8) **Output - heating element L3**
- (9) **Input - grid supply** 3x 230 V, spring-type terminal 1.5 - 2.5 mm²
- (10) **Automatic circuit breaker** max. B16A
- (11) **Residual current circuit breaker**

IMPORTANT! Plug & Play - In this application, no further settings are required after successful connection to the inverter.

The Fronius Smart Meter records the current power at the feed-in point and transmits the data to the inverter. The inverter adjusts the available surplus energy to zero by activating the Ohmpilot (specifically by continuously controlling the heating element connected to the Ohmpilot). This means that the surplus energy is consumed by the heating element (steplessly variable). Depending on the excess power available, the individual phases are switched on or off and the remaining power is consumed at L1. As a result, the heating element output is divided by three.

If no temperature sensor is installed, a third-party source (e.g., gas boiler) must ensure the minimum temperature.

As an alternative, the Ohmpilot can ensure the minimum temperature. To do this, a temperature sensor must be connected so that the Ohmpilot can measure the temperature. This can result in electricity being drawn from the grid.

The maximum temperature must be set on the heating element thermostat. If the heating element does not have a thermostat, the Ohmpilot can also carry out this task as an alternative (see chapter [Optional settings](#) on page 46).

IMPORTANT! A neutral conductor must be connected to the heating element.

1-phase heating element up to 3 kW with heat pump control

Application example 3

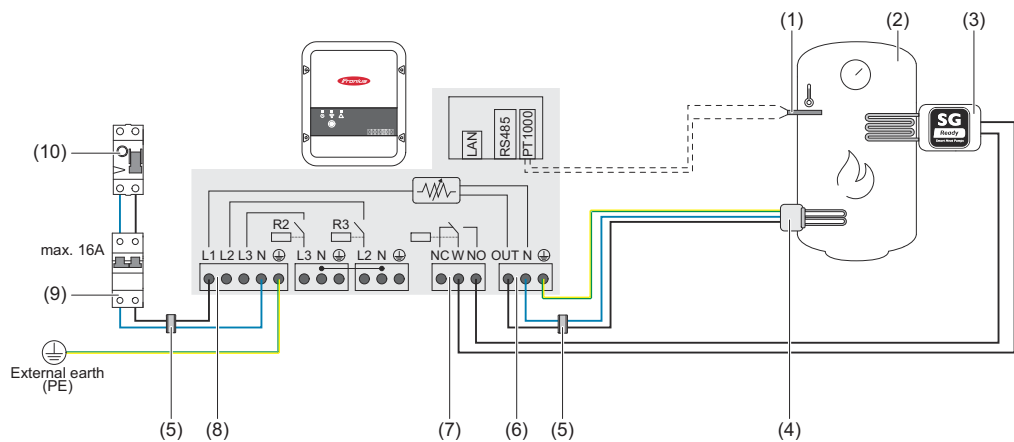

IMPORTANT! A neutral conductor must be connected to the heating element.

- (1) **Temperature sensor** PT1000
- (2) **Hot water boiler**
- (3) **Heat pump** with SG Ready control input
- (4) **Heating element** (max. 3 kW)
- (5) **Ferrite rings** (included in the scope of supply)
- (6) **Output up to 3 kW** (adjustable), max. 13 A ohmic load, spring-type terminal 1.5 - 2.5 mm²
- (7) **Multifunctional relay output**

NOTE!

Relay contacts can oxidize.

The voltage must be at least 15 V and the current at least 2 mA so that the relay contacts do not oxidize.

- (8) **Input - grid supply** 1x 230 V, spring-type terminal 1.5 - 2.5 mm²

⚠ CAUTION!

Danger due to live stripped wires coming into contact with each other

A short circuit can be triggered and damage the device.

- ▶ All connection work must be carried out according to the applicable electro-technical guidelines and regulations.
- ▶ Observe the maximum stripping length of 10 mm.
- ▶ When connecting the phases, tie together the individual wires with a cable tie immediately in front of the terminal.

- (9) **Automatic circuit breaker** max. B16A
- (10) **Residual current circuit breaker**

The Fronius Smart Meter records the current power at the feed-in point and transmits the data to the inverter. The inverter adjusts the available surplus energy to zero by activating the Ohmpilot (specifically by continuously controlling the heating element connected to the Ohmpilot and through targeted activation of the heat pump).

In order to be controlled in this way, the heat pump must have a control input (SG Ready or utility release). The heat pump can be switched from normal operation to intensified operation by actuating input 2 of the heat pump with the relay. The heat pump can also be switched to normal operation from a utility lock state by actuating input 1 of the heat pump with the relay. Information on the compatibility of the heat pump with this form of control can be found in the operating instructions of the respective device.

Smaller surpluses are consumed by the heating element (stepless adjustment). From a certain surplus power level, the heat pump should be activated due to the higher efficiency. The average COP (Coefficient Of Performance) for water heating up to 53 °C is 2.5. With 1 kW of electrical energy, 2.5 kW of thermal energy can be generated.

The optimal switching times depend on the following factors:

- COP of the heat pump. The higher the hot water is heated, the lower the COP.
- Output of the electrical heat pump.
- Feed-in tariff and the energy purchase price.
- Reducing the start-up cycles of the heat pump = longer service life of the heat pump.
- Thermal losses of the heat pump and the pipelines.

If no temperature sensor is installed, the heat pump must ensure the minimum temperature. As an alternative, the Ohmpilot can also ensure the minimum temperature through activation of the heat pump. This can result in electricity being drawn from the grid. The maximum temperature must be set on the heating element thermostat and on the heat pump. If the heating element does not have a thermostat, the Ohmpilot can also carry out this task as an alternative (see chapter [Optional settings](#) on page 46).

This function **can also be used with a 3-phase heating element.**

Settings in menu area

The screenshot shows the 'GENERAL SETTINGS' page of the Fronius Ohmpilot interface. At the top, there are navigation tabs for 'OHMPILOT', 'GENERAL', and 'NETWORK', with 'GENERAL' selected. The 'Designation' field is set to 'Ohmpilot'. Under 'HEATER 1', the 'Automatic' mode is selected, and the 'Consumer' is set to 'Single-phase' with a 'Power (W)' of 3000. A checkbox for 'Temperature sensor present' is unchecked. Under 'HEATER 2', the 'Consumer' is set to 'SG Ready heat pump'. The 'Starting threshold' is set to 'Feed-in' with a value of 3000 W, and the 'Switch off threshold' is set to 'Consume' with a value of 500 W. A red 'Save' button is located at the bottom left of the settings area.

General settings, symbolic representation

- 1 Open the user interface of the Ohmpilot (see chapter [Establishing the data connection](#)).
- 2 Select **SG Ready heat pump** under **Heater 2 > Consumer**.
- 3 Under **Starting threshold > Feed-in**, select and enter the desired power in watts at which the heat pump should be switched on.
- 4 Under **Switch off threshold > Consume or Feed-in**, select and enter the desired power in watts at which the heat pump is to be switched off.

Example 1: If "Consume" has been selected for the switch-off threshold and 500 W as the power value, the heat pump is switched off as soon as consumption exceeds 500 W.

Example 2: If "Feed-in" has been selected for the switch-off threshold and a power of 500 W has been entered, the heat pump will be switched off as soon as the power being fed in is less than 500 W.

NOTE!

The heat pump must be connected to the same utility meter.

Between the switch-on and switch-off thresholds, the heat pump's self-consumption must also be taken into account. For example, if the heat pump consumes 3,000 watts and a hysteresis of 500 watts is to be taken into account again, the switch-on threshold can be set to a feed-in value of 3,000 watts and the switch-off threshold to a consumption value of 500 watts.

1-phase heating element up to 3 kW and external source

Application example 4

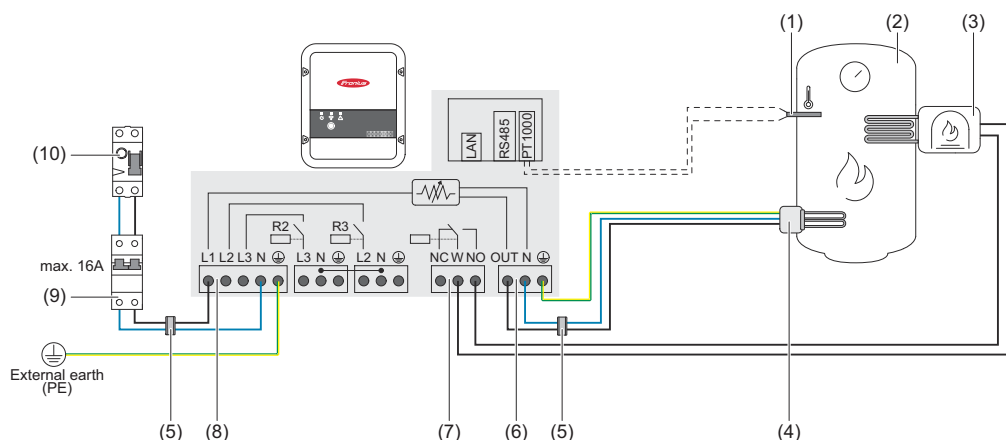

IMPORTANT! A neutral conductor must be connected to each heating element.

- (1) **Temperature sensor** PT1000
- (2) **Hot water boiler**
- (3) **External source** (e.g., gas boiler)

NOTE!

Relay contacts can oxidize.

The voltage must be at least 15 V and the current at least 2 mA so that the relay contacts do not oxidize.

- (4) **Heating element** (max. 3 kW)
- (5) **Ferrite rings** (included in the scope of supply)
- (6) **Output up to 3 kW** (adjustable), max. 13 A ohmic load, spring-type terminal 1.5 - 2.5 mm²
- (7) **Multifunctional relay output**
- (8) **Input - grid supply** 1x 230 V, spring-type terminal 1.5 - 2.5 mm²

⚠ WARNING!

Short circuit

If live, stripped wires touch, a short circuit is triggered.

- ▶ All connection work must be carried out according to the applicable electro-technical guidelines and regulations.
- ▶ Observe the maximum stripping length of 10 mm.
- ▶ When connecting the phases, tie together the individual wires with a cable tie immediately in front of the terminal.

- (9) **Automatic circuit breaker** max. B16A
- (10) **Residual current circuit breaker**

The Fronius Smart Meter records the current power at the feed-in point and transmits the data to the inverter. The inverter adjusts the available surplus energy to zero by activating the Ohmpilot (specifically by continuously controlling the heating element connected to the Ohmpilot). The surplus energy is consumed by the heating element (steplessly variable).

The temperature is measured by the Ohmpilot. If the temperature drops below the minimum temperature value, an external source (e.g., gas boiler) is activated until the minimum temperature is reached again, so that the Ohmpilot only uses surplus energy and does not draw any energy from the grid.

The maximum temperature must be set on the heating element thermostat. If the heating element does not have a thermostat, the Ohmpilot can also carry out this task as an alternative (see chapter [Optional settings](#) on page 46).

The heating element is used for the legionella prevention program.

This function **can also be used with a 3-phase heating element.**

Settings in menu area

GENERAL SETTINGS

Designation: Ohmpilot

HEATER 1

Automatic
 Manual
 Measure heating element:

Consumer: Single-phase
 Power (W): 3000

Temperature sensor present
 Legionella prevention (h)

Adapt day curve
 Maximum temperature

Time from:	Time to:	Minimum temperature:
<input checked="" type="checkbox"/> 06:00	11:00	45 °C
<input checked="" type="checkbox"/> 11:00	13:00	50 °C
<input checked="" type="checkbox"/> 13:00	21:00	45 °C
<input checked="" type="checkbox"/> 21:00	06:00	40 °C

HEATER 2

Consumer: Activate external source

Save

General settings, symbolic representation

- 1 Open the user interface of the Ohmpilot (see chapter [Establishing the data connection](#)).
- 2 Enable the **Temperature sensor present** field.
- 3 Enable the **Adapt day curve** field.
- 4 Set the **Time from**, **Time to**, and **Minimum temperature** values as desired. For more information, see chapter [Adapting the day curve](#)
- 5 Select **Activate external source** under **Heater 2 > Consumer**.

Two heating elements - 3-phase and 1-phase

Application example 5

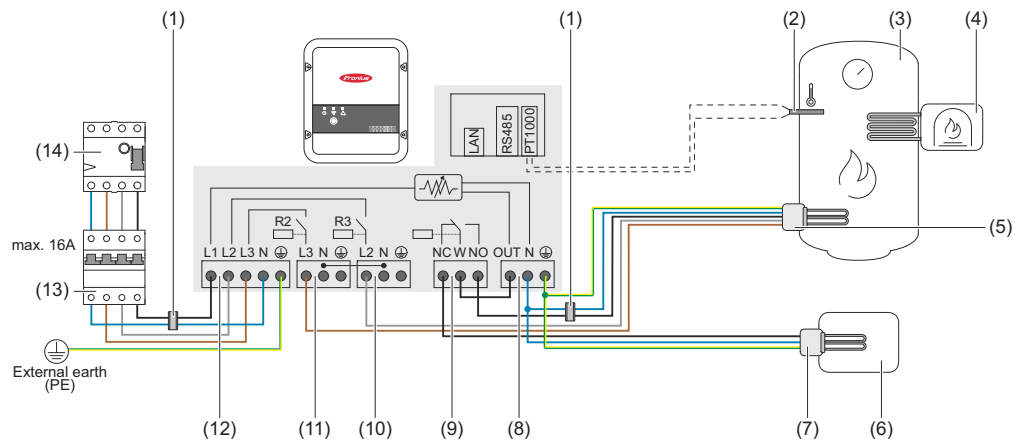

IMPORTANT! A neutral conductor must be connected to each heating element.

- (1) **Ferrite rings** (included in the scope of supply)
- (2) **Temperature sensor** PT1000
- (3) **Hot water boiler**
- (4) **External source** (e.g., gas boiler)
- (5) **Heating element 1** (max. 3 kW)
- (6) **Buffer**
- (7) **Heating element 2** (max. 9 kW)
- (8) **Output up to 3 kW** (adjustable), max. 13 A ohmic load, spring-type terminal 1.5 - 2.5 mm²
- (9) **Multifunctional relay output**
- (10) **Output - heating element L2**
- (11) **Output - heating element L3**
- (12) **Input - grid supply** 3x 230 V, spring-type terminal 1.5 - 2.5 mm²
- (13) **Automatic circuit breaker** max. B16A
- (14) **Residual current circuit breaker**

Many heating systems consist of a boiler and a buffer, whereby the central heating feeds the buffer and a controller loads the hot water boiler via a pump. As with thermal photovoltaic systems, the Ohmpilot can first heat the hot water boiler and then the buffer, so that the maximum surplus PV energy can be stored.

The Fronius Smart Meter records the current power at the feed-in point and transmits the data to the inverter. The inverter adjusts the available surplus energy to zero by activating the Ohmpilot (specifically by continuously controlling the heating element connected to the Ohmpilot).

For this application, two heating elements are installed, with preference being given to activating the first heating element (5). Only when the maximum temperature in the boiler (3) is reached is the second heating element activated so that the residual energy is stored, for example, in a buffer.

If no temperature sensor is connected to the Ohmpilot, after 30 minutes the Ohmpilot attempts to output energy via the first heating element once again. If a temperature sensor is present, the first heating element is activated again as

soon as a temperature difference of 8°C is reached (compared to the temperature measured prior to switchover).

This switching function can also be used for layering in a boiler/buffer, so that the maximum temperature is reached in the top part of the boiler using minimal energy and the remaining energy is stored in the lower part of the boiler. This stratification effect in a storage tank also allows much more energy to be stored, as a minimum temperature is normally maintained in the upper area of the boiler. As a result, the temperature difference and thus the amount of energy is rather small. In the lower area of the boiler, a high temperature difference of, for example, 50 °C can be used.

Both the first and second heating elements can be 1-phase or 3-phase. For two 3-phase heating elements, see [Application example 6](#). If no temperature sensor is installed, a third-party source (e.g., gas boiler) must ensure the minimum temperature.

As an alternative, the Ohmpilot can also ensure the minimum temperature. This can result in electricity being drawn from the grid. The maximum temperature must be set on the heating element thermostat. If heating element 1 (5) does not have a thermostat, the Ohmpilot can alternatively take over this task (see chapter [Optional settings](#) on page 46). However, it is essential that heating element 2 (7) has a thermostat.

NOTE!

It is not possible to heat both heating elements at the same time!

Settings in menu area

The screenshot shows the 'GENERAL SETTINGS' menu of the Fronius Ohmpilot. The 'Designation' is set to 'Ohmpilot'. Under 'HEATER 1', the 'Automatic' radio button is selected, and the 'Consumer' is set to 'Single-phase' with a power of 3000 W. Under 'HEATER 2', the 'Consumer' is set to 'Three-phase' with a power of 4500 W. A 'Save' button is located at the bottom of the settings area.

General settings, symbolic representation

- 1 Open the user interface of the Ohmpilot (see chapter [Establishing the data connection](#)).
- 2 Select **Manual** and **Single-phase** or **Three-phase** under **Heater 1**.
- 3 Select **Single-phase** or **Three-phase** and enter the power of the consumer under **Heater 2**.

Two 3-phase heating elements up to 9 kW

Application example 6

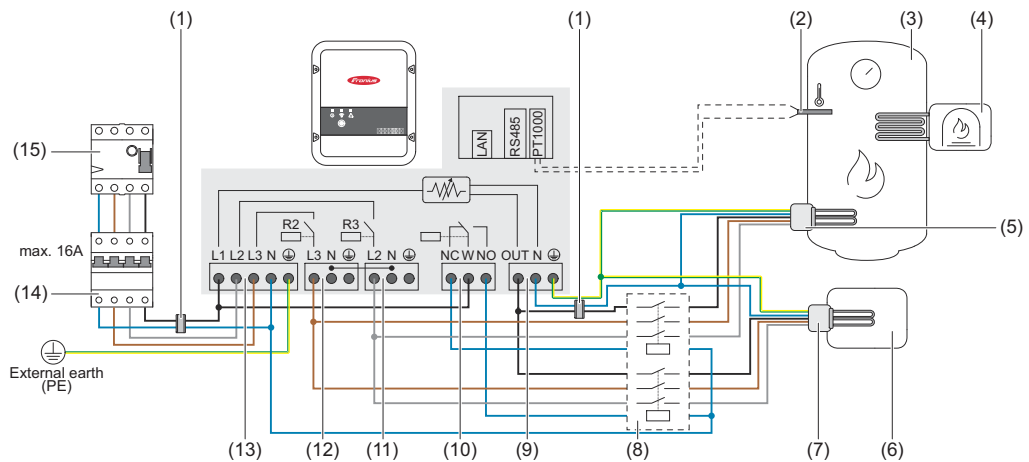

IMPORTANT! A neutral conductor must be connected to each heating element.

- (1) **Ferrite rings** (included in the scope of supply)
- (2) **Temperature sensor** PT1000
- (3) **Hot water boiler**
- (4) **External source** (e.g., gas boiler)
- (5) **Heating element 1** (max. 9 kW)
- (6) **Buffer**
- (7) **Heating element 2** (max. 9 kW)
- (8) **Contactor changeover**
- (9) **Output up to 3 kW** (adjustable), max. 13 A ohmic load, spring-type terminal 1.5 - 2.5 mm²
- (10) **Multifunctional relay output**
- (11) **Output - heating element L2**
- (12) **Output - heating element L3**
- (13) **Input - grid supply** 3x 230 V, spring-type terminal 1.5 - 2.5 mm²
- (14) **Automatic circuit breaker** max. B16A
- (15) **Residual current circuit breaker**

Many heating systems consist of a boiler and a buffer, whereby the central heating feeds the buffer and a controller loads the hot water boiler via a pump. As with thermal photovoltaic systems, the Ohmpilot can first heat the hot water boiler and then the buffer, so that the maximum surplus PV energy can be stored.

The Fronius Smart Meter records the current power at the feed-in point and transmits the data to the inverter. The inverter adjusts the available surplus energy to zero by activating the Ohmpilot (specifically by continuously controlling the heating element connected to the Ohmpilot).

For this application, two heating elements are installed, with preference being given to activating the first heating element (5). Only when the maximum temperature in the boiler (3) is reached is the second heating element (7) activated so that the residual energy is stored, for example, in a buffer.

If no temperature sensor is connected to the Ohmpilot, after 30 minutes the Ohmpilot attempts to output energy via the first heating element once again. If a temperature sensor is present, the first heating element is activated again as

soon as a temperature difference of 8°C is reached (compared to the temperature measured prior to switchover).

This switching function can also be used for layering in a boiler/buffer, so that the maximum temperature is reached in the top part of the boiler using minimal energy and the remaining energy is stored in the lower part of the boiler. This stratification effect in a storage tank also allows much more energy to be stored, as a minimum temperature is normally maintained in the upper area of the boiler. The temperature difference and thus the amount of energy is rather small. In the lower area of the boiler, a high temperature difference of, for example, 50 °C can be used.

The switchover must be performed by an external contactor. If no temperature sensor is installed, a third-party source (e.g., gas boiler) must ensure the minimum temperature.

As an alternative, the Ohmpilot can also ensure the minimum temperature. This can result in electricity being drawn from the grid.

The maximum temperature must be set on the heating element thermostat. If heating element 1 (5) does not have a thermostat, the Ohmpilot can alternatively take over this task (see chapter [Optional settings](#) on page 46). However, it is essential that heating element 2 (7) has a thermostat.

NOTE!

It is not possible to heat both heating elements at the same time!

Settings in menu area

The screenshot shows the 'GENERAL SETTINGS' page of the Ohmpilot interface. At the top, there are navigation tabs for 'OHMPILOT', 'GENERAL', and 'NETWORK', with 'GENERAL' selected. The 'Designation' field is set to 'Ohmpilot'. Under 'HEATER 1', the 'Automatic' radio button is selected, and the 'Manual' option is unselected. The 'Consumer' is set to 'Three-phase' and the 'Power (W)' is set to '3000'. There is an unchecked checkbox for 'Temperature sensor present'. Under 'HEATER 2', the 'Consumer' is set to 'Three-phase' and the 'Power (W)' is set to '3000'. A 'Save' button is located at the bottom left of the settings area.

General settings, symbolic representation

- 1 Open the user interface of the Ohmpilot (see chapter [Establishing the data connection](#)).
- 2 Select **Three-phase** and enter the power of the consumer under **Heater 2**.

1-phase heating element up to 3 KW / 3-phase heating element and circulation pump

Application example 7

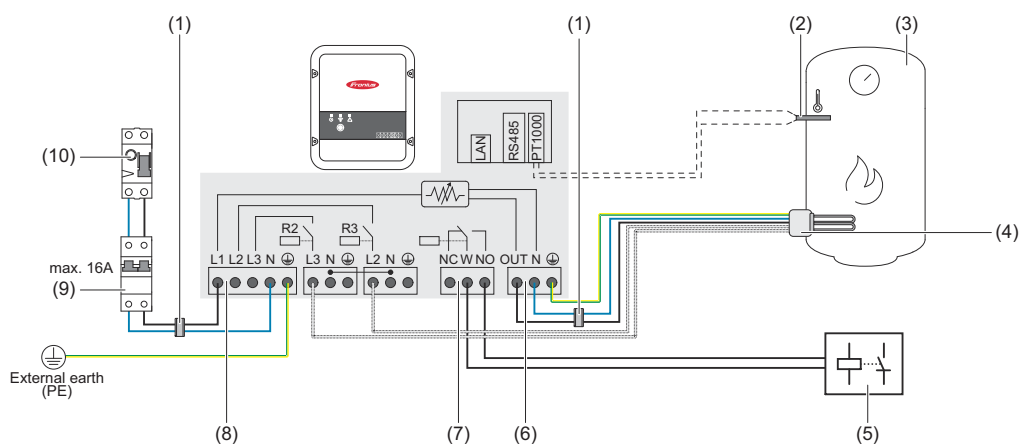

IMPORTANT! A neutral conductor must be connected to each heating element.

- (1) **Ferrite rings** (included in the scope of supply)
- (2) **Temperature sensor** PT1000
- (3) **Hot water boiler**
- (4) **Heating element**

NOTE!

Single-phase and three-phase heating element

This function can be used with a single-phase and three-phase heating element.

- (5) **Circulating pump auxiliary relay**

NOTE!

Post-flow time of the circulating pump

After the end of the heating operation, the circulating pump is active for 60 seconds.

- (6) **Output up to 3 kW** (adjustable), max. 13 A ohmic load, spring-type terminal 1.5 - 2.5 mm²
- (7) **Multifunctional relay output**

NOTE!

Relay contacts can oxidize.

The voltage must be at least 15 V and the current at least 2 mA so that the relay contacts do not oxidize.

(8) **Input - grid supply** 1x 230 V, spring-type terminal 1.5 - 2.5 mm²

⚠ CAUTION!

Danger due to live stripped wires coming into contact with each other

A short circuit can be triggered and damage the device.

- ▶ All connection work must be carried out according to the applicable electro-technical guidelines and regulations.
- ▶ Observe the maximum stripping length of 10 mm.
- ▶ When connecting the phases, tie together the individual wires with a cable tie immediately in front of the terminal.

(9) **Automatic circuit breaker** max. B16A

(10) **Residual current circuit breaker**

The Ohmpilot can also control a circulating pump in a heating system in parallel to a heating element via the floating contact of the device controller. This is possible with all circulating pumps that have an auxiliary relay.

The designation of the floating contact on the Ohmpilot is **NC W NO**. When the contact is activated, the switching rocker (W) switches from the "normally open" (NO) position to "normally closed" (NC).

In heating operation, this contact is activated and the circulating pump runs as **Heater 2** in parallel to the heating element, which is operated via the output **Heater 1**.

To prevent the auxiliary relay of the circulating pump from switching on and off continuously in case of low or fluctuating PV power, the Ohmpilot is equipped with a delay. This has a positive effect on the wear and the service life of the relay and the pump.

Settings in menu area

The screenshot shows the 'GENERAL SETTINGS' menu of the Fronius Ohmpilot. The 'GENERAL' tab is selected. Under 'HEATER 1', the 'Automatic' radio button is selected, and the 'Consumer' dropdown menu is open, showing 'Circulating pump' as the selected option. Other settings include 'Power (W)' set to 1002, 'Temperature sensor present' checked, 'Maximum temperature' set to 70°C, and 'Adapt day curve' unchecked. A 'Save' button is visible at the bottom left.

General settings, symbolic representation

- 1 Open the user interface of the Ohmpilot (see chapter [Establishing the data connection](#)).
- 2 Select **Automatic** under **Heater 1**.

3 Select **Circulating pump** under **Heater 2**.

IMPORTANT!

If the circulating pump option is selected, no other heater can be controlled by the Ohmpilot. The output **Heater 1** controls the heating element, which, in combination with the circulating pump, heats a hot water tank.

Establishing the data connection

Possible communication channels

The data connection is required for communication between the inverter and the Ohmpilot. The inverter mainly sends default values to the Ohmpilot. For some applications, it is necessary to make settings via the Ohmpilot user interface.

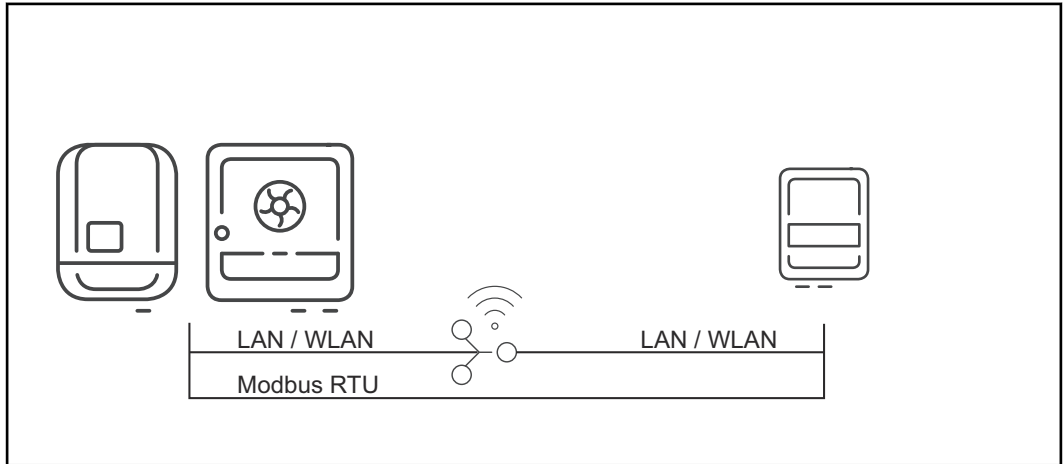

There are 3 possible communication channels:

- Modbus RTU (via RS 485)
- LAN (Ethernet)
- WLAN

NOTE!

Fronius Datamanager 2.0 software version

In order to communicate with the Ohmpilot, software version 3.8.1-x onwards must be installed on the SnapINverter series inverter (Fronius Datamanager 2.0).

Pairing the inverter with the Ohmpilot

Each inverter with a Fronius Smart Meter automatically pairs with the Ohmpilot. If there are several inverters with a Fronius Smart Meter in the network, the Ohmpilot must be manually paired under System Information on the user interface of the inverter to be connected.

Guidance on how to access the user interface of the inverter can be found in the operating instructions of the respective device.

Establishing a connection via Modbus RTU

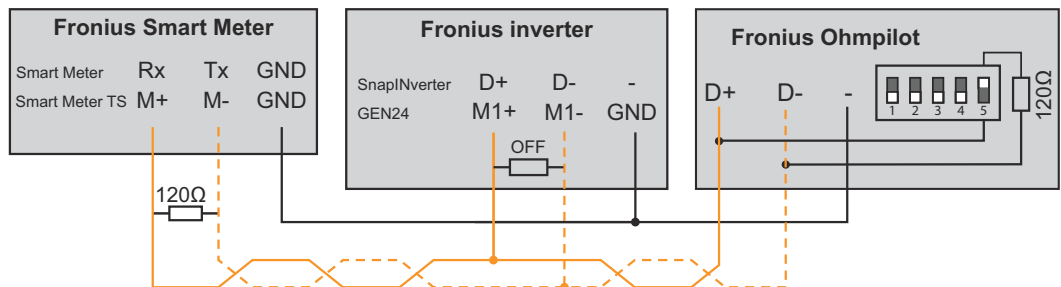

Ohmpilot connections	Fronius Smart Meter connections	Fronius SnapIN-verter / GEN24 connections
D+	Rx / M+	D+ / M1+
D-	Tx / M-	D- / M1-
-	GND	GND

⚠ WARNING!

Danger if cables are mixed up

If data cables and live mains cables are mixed up, this can result in personal injury and damage to property.

- ▶ Use data cables that are clearly distinguishable from the mains cables.
- ▶ Mark cables (e.g., by labeling)

NOTE!

Defective cabling is signaled by the red LED indicator flashing once.

- 1 Connect the data communication cable in parallel to the Ohmpilot and system components.
- 2 Activate the terminating resistor on the first and last device of the Modbus cable. Activate the resistor on the Ohmpilot with DIP switch number 5.
- 3 Set the Modbus address using DIP switches 1-3.
Default address: 40 (for future applications, the Modbus address can be changed using the DIP switches on the Ohmpilot.)

DIP switch settings

Switch	Setting
DIP 1-3	Modbus address BCD
DIP 4	Reserve
DIP 5	Terminating resistor (120 Ohm)

Establish a WLAN connection to implement further settings:

- 1 Press the button on the Ohmpilot 2x.
The blue LED flashes twice. The WLAN access point is activated for 30 minutes.
- 2 Activate the "Ohmpilot" WLAN network on the mobile device or PC.
- 3 In the browser, enter the address <http://192.168.250.181> or <http://ohmpilotW.local>.
- 4 Continue configuration on the user interface.

Establishing a connection via LAN

The Ohmpilot automatically obtains its IP address from the DHCP server.

The inverter automatically searches for the Ohmpilot, and the search process may take up to 5 minutes. If the red LED is unlit and the green LED is flashing, the Ohmpilot is working correctly.

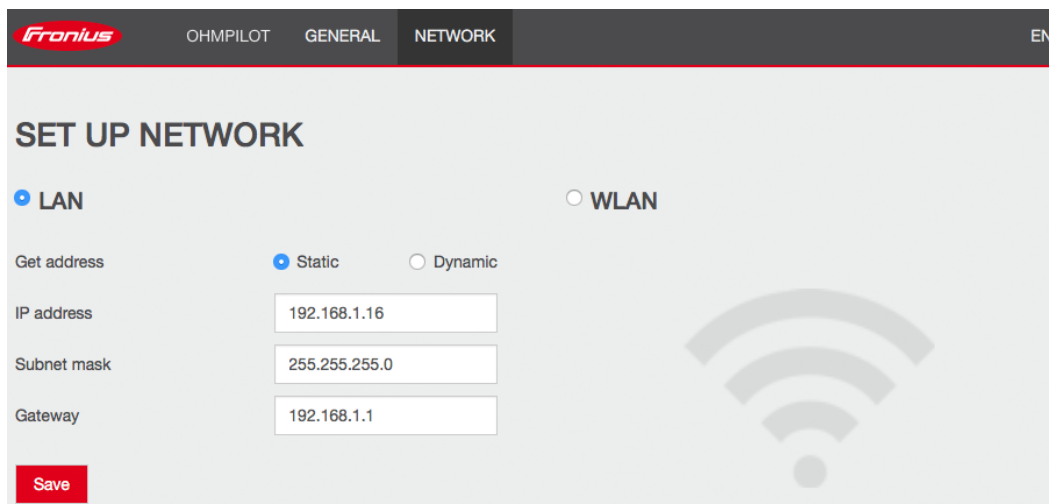

Setting up the network, symbolic representation

- 1 Open the address <http://ohmpilotL.local> in the web browser.
- 2 Alternatively, search for the Ohmpilot in the network using the Fronius Solar.start app.

NOTE!

Access the Ohmpilot via the network.

In networks with a DNS suffix, the Ohmpilot can be reached at <http://ohmpilotL.<DNS suffix>>, e.g., <http://ohmpilotL.fronius.com>

In order to set the IP address manually, the option **Static** must be selected. Then enter the desired IP address.

Establishing a connection via WLAN

There are two options for connecting the Ohmpilot to an existing WLAN network:

1. Establishing a connection via WPS (Wi-Fi Protected Setup)

- 1 Press the button on the Ohmpilot once.
The blue LED flashes for as long as WPS is active.
- 2 Press the WPS button on the router within 2 minutes.
If the blue LED on the Ohmpilot lights up continuously, the network connection is active.
The inverter automatically searches for the Ohmpilot. The search process can take up to 5 minutes. If the red LED is unlit and the green LED is flashing, the Ohmpilot is working correctly.

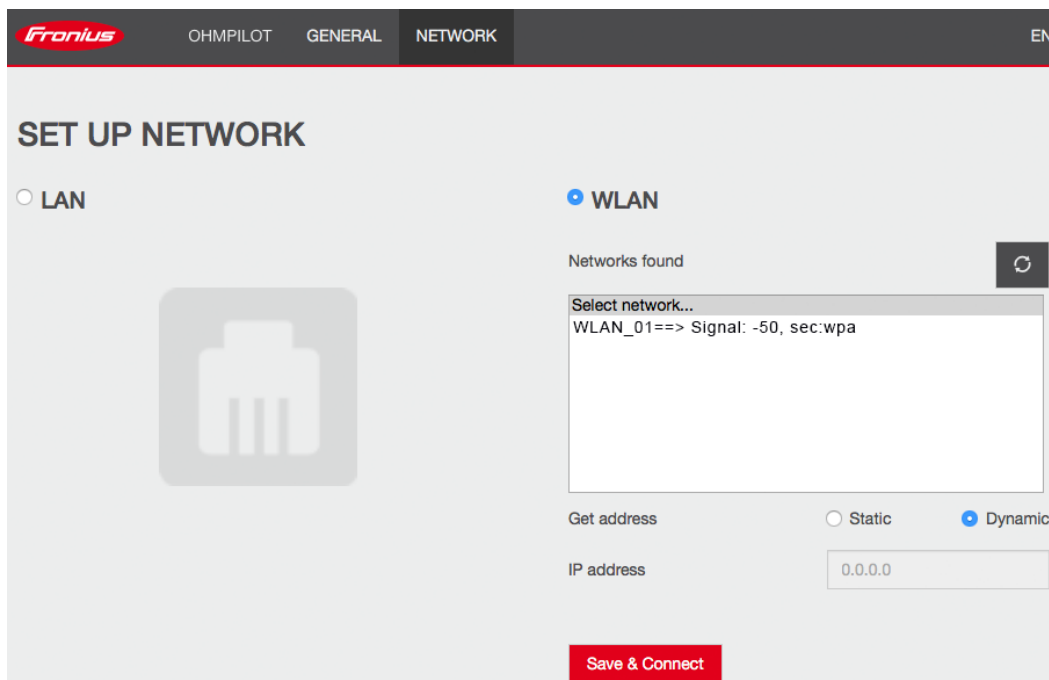

Setting up the network, symbolic representation

2. Connection via access point and manual configuration of WLAN settings

- 1 Press the function button on the Ohmpilot twice.
The blue LED flashes twice for as long as the WLAN access point is active (30 minutes). Before the access point is opened, the Ohmpilot searches for available WLAN networks.
- 2 Enable the WLAN network "Ohmpilot" on the smart device or PC.
- 3 Enter the address <http://192.168.250.181> or <http://ohmpilotW.local> in the browser. Alternatively, the Ohmpilot can also be searched for in the network using the Fronius Solar.start app.
- 4 Select the desired network in the WLAN network tab.

NOTE!

Network scan

WLAN network scan is not possible when the access point mode is activated.

- ▶ End the access point mode by pressing the button again and repeat the process

- 5 Click **Save & Connect**, enter the WLAN password.
If the blue LED on the Ohmpilot is permanently lit, the connection to the network has been successful.
The inverter will automatically search for the Ohmpilot, which may take up to 5 minutes. If the red LED is unlit and the green LED is flashing, the Ohmpilot is working correctly.

The user interface can be used to set a static IP address for the Ohmpilot.

The Ohmpilot can then be reached at <http://ohmpilotW.local> or at the fixed IP address assigned. Alternatively, the Ohmpilot can also be searched for in the network using the Fronius Solar.web app.

NOTE!

Connection to the inverter

Only one inverter can connect to the Ohmpilot.

NOTE!

DNS networks

In networks with a DNS suffix, the Ohmpilot is available at [http:// ohmpilotW.<DNS suffix>](http://ohmpilotW.<DNS suffix>), e.g., <http://ohmpilotW.fronius.com>

Boost Mode

Boost mode

Boost mode is used to briefly supply loads on output **Heater 1** with 100% of the available power. Over a maximum period of 4 hours, the dimming level is activated at 100%, the phases L2 and L3 are switched through. This can result in electricity being drawn from the grid.

Boost mode can be activated and deactivated by pressing the function button on the Ohmpilot (see [Indications/controls on the device](#)) or via the user interface.

Settings in menu area

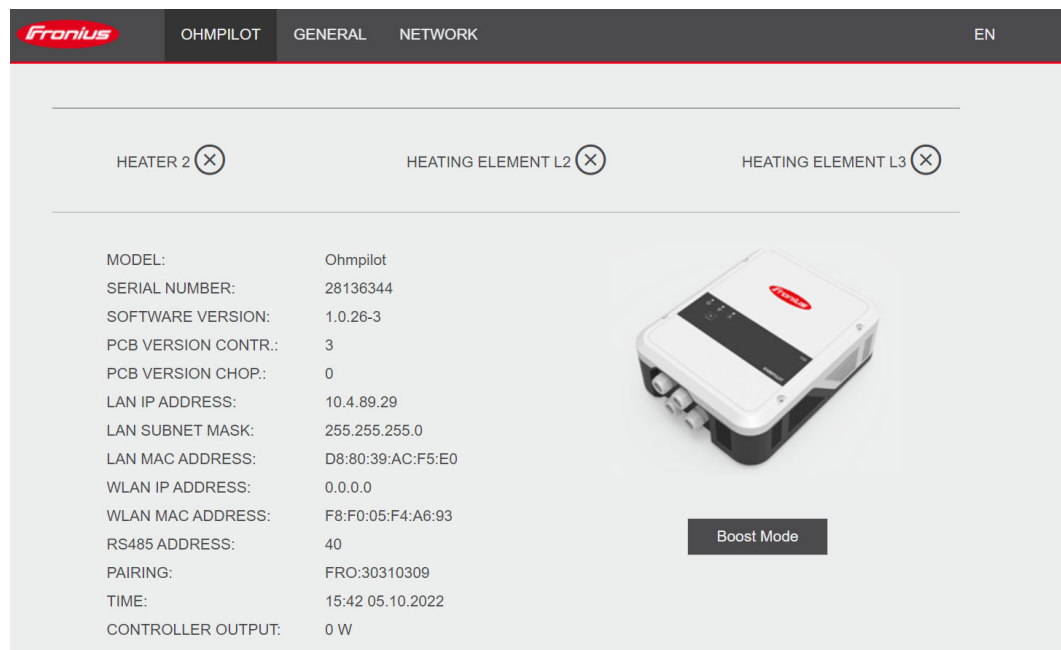

Boost mode, symbolic representation

- 1 Open the user interface of the Ohmpilot (see chapter [Establishing the data connection](#)).
- 2 Click **Boost Mode** to activate the function.
- 3 Click again to deactivate **boost mode**.

User interface

Status display

The screenshot shows the Fronius Ohmpilot user interface. At the top, there are navigation tabs for 'OHMPILOT', 'GENERAL', and 'NETWORK', along with a language selector 'EN'. The main display area is divided into several sections:

- Status:** A heart icon with 'OK' and 'STATUS' below it.
- Temperature:** A thermometer icon with '24.5 °C' and 'TEMPERATURE' below it.
- Heating Output:** A power icon with '0 W' and 'HEATING OUTPUT' below it.
- Heating Elements:** Three indicators for 'HEATER 2', 'HEATING ELEMENT L2', and 'HEATING ELEMENT L3', each with a circled 'X' icon.
- Technical Data:** A list of system parameters including Model, Serial Number, Software Version, PCB versions, LAN/WLAN IP and MAC addresses, RS485 address, pairing ID, time, and controller output.
- Device Image:** A photograph of the Ohmpilot device with a 'Boost Mode' button overlaid on it.

Status display, symbolic representation

Status

OK	Ohmpilot is operating in normal mode.
Minimum temperature	The minimum temperature has been undershot. Heater 1 heats up to 100%.
Legionella prevention	Legionella prevention program is active. Heater 1 heats up to 100%.
Boost	The Ohmpilot was manually set to Boost Mode. Heater 1 heats up to 100%.
Error	An error has been detected. Further information is displayed in Fronius Solar.web.
Temperature	Current measured temperature. A valid value is only displayed when a temperature sensor is connected.
Heat output	Current power being used by the Ohmpilot.
Heater 2	Heater 2 is active. Heater 2 may be a second heating element, a heat pump, or an external source (e.g., gas-fired heating).
L2 heating element	Phase 2 of 3-phase heating element is active.
L3 heating element	Phase 3 of 3-phase heating element is active.

Optional settings

HEATER 1 manual settings

NOTE!

Applicability

The settings described here can be made for all the application examples described above.

The screenshot shows the 'GENERAL SETTINGS' page for the 'Ohmpilot' device. The 'HEATER 1' section is active, with 'Manual' selected. The 'Consumer' is set to 'Three-phase' and the 'Power (W)' is 3000. There are checkboxes for 'Temperature sensor present', 'Adapt day curve', 'Legionella prevention (h)', and 'Maximum temperature'. The 'Time from:' and 'Time to:' sections show a schedule with times like 03:00, 16:00, 20:28, and 20:25. The 'Minimum temperature:' section shows values of 45, 45, 52, and 53 °C. A 'Save' button is at the bottom.

General settings, symbolic representation

Set the power of HEATER 1 manually:

- 1 Select **Manual** under **Heater 1**.
- 2 Select **Single-phase** or **Three-phase** for **Consumer**
- 3 Enter the consumer power

NOTE!

Automatic measurement of heating element 1

In the case of applications with a 1-phase and a 3-phase heating element, it is not possible for the Ohmpilot to measure heating element 1 automatically due to the cabling. In this case, the configuration must be carried out manually.

Activating Legionella prevention

CAUTION!

Danger from Legionella

Legionella bacteria can cause serious diseases. Despite the **Legionella prevention function**, the possibility of water contamination with Legionella cannot be excluded.

- ▶ Run the Legionella prevention function regularly.
 - ▶ Ensure continuous circulation and removal of hot water.
 - ▶ Check hot water temperature regularly
-

NOTE!

If the boiler is operated at a temperature of less than 60°C for a longer period of time and no hygiene storage tank is being used, appropriate measures must be taken to kill Legionella bacteria.

- ▶ For the private sector, it is recommended to run the Legionella prevention function at least once a week (168 hours). The actual interval depends on the size of the tank and the set temperature.
 - ▶ A PT1000 temperature sensor is required for this function, which can be obtained from Fronius under item number 43,0001,1188.
-

When the Legionella prevention function is activated, the hot water is heated to 60 °C at the set interval.

- 1 Enable the **Temperature sensor present** field
 - 2 Enable the **Legionella prevention (h)** field
 - 3 Enter the desired cycle for Legionella prevention
-

Adapting the day curve

This function ensures that the temperature does not fall below a desired value. If there is not enough surplus power, the external source - if activated - is activated or power is drawn from the grid to ensure a minimum temperature.

Up to four time periods and minimum temperatures can be defined. For example, higher hot water temperatures are available in the evening. More potential for the surplus power during the day is then possible by selecting a lower minimum temperature.

Adapting the day curve:

- 1 Enable the **Temperature sensor present** field
- 2 Enable the **Adapt day curve** field
- 3 Under **Time from**, enter the time from which the Ohmpilot should start to heat to the new minimum temperature.
- 4 Under **Time to**, enter the time until which the Ohmpilot should heat to the minimum temperature.
- 5 Under **Minimum temperature**, enter the desired end temperature.

NOTE!

Undefined time ranges.

If no time ranges are defined, no heating will be carried out using energy from the grid or the external source during this time. Only PV surplus energy is used.

NOTE!

If time ranges overlap, the higher temperature is used, so that, for example, a basic temperature of 40° C can be set for the whole day and is increased to 50° C at certain times.

NOTE!**Primary heat source.**

If Heater 1 is the primary heat source, the day curve must be adjusted to ensure the desired minimum temperature. A PT1000 temperature sensor is required for this function, which can be obtained from Fronius under item number 43,0001,1188. The temperature sensor must be mounted above the heating element/external source so that the continuous supply of hot water is ensured.

Example**Time/Desired temperature****Use case**

03:00 - 05:00 / 45°C

So that hot water is available for showering at 6:00 in the morning. After showering, the hot water is only heated with surplus energy.

16:00 - 18:00 / 45°C

If there is not enough surplus energy, the hot water is re-heated for showering. After showering, there is no more reheating of the tank, so the heat losses remain low.

Temperature limitation

If Heater 1 does not have an adjustable thermostat, this function can be used to limit the temperature.

- 1** Enable the **Temperature sensor present** field
- 2** Enable the **Temperature limitation** field
- 3** Enter maximum temperature (e.g., 60 ° C)

NOTE!**This function is only possible for Heater 1.**

If a second heating element is being used as Heater 2, it must have a thermostat. A PT1000 temperature sensor is required for this function, which can be obtained from Fronius under item number 43,0001,1188. The position of the temperature sensor should be just above the heating element, so that the incoming cold water is immediately heated again and thus the maximum amount of storage is used.

Appendix

Status codes

Status codes

Error transmission

- Errors are stored in Fronius Datamanager 2.0 and can be sent via Fronius Solar.web.
- Possible error outputs:

Status codes

HS = Heating element TS= Temperature sensor WR = Inverter FQ = External source (e.g., gas boiler)

Code	Description	Cause	Remedy
906	Heating element 1 defective - Short circuit L1	The load on L1 is higher than 3 kW. Short circuit to L1.	Check heating element 1. Check cabling.
907	HS 1 - Overload on L2	Current on L2 greater than 16 A	Check HS 1 and replace HS if necessary.
908	HS 1 - Overload on L3	Current on L3 greater than 16	
909	HS 1 defective - L1 high-resistance	No current flowing through L1/L2/L3. L1/L2/L3 of HS 1 defective. Phase L1/L2/L3 interrupted.	Check L1/L2/L3. Check connections L1/L2/L3.
910	HS 1 defective - L2 high-resistance		
911	HS 1 defective - L3 high-resistance		
912	HS 2 defective - Short circuit L1	The load on L1 is higher than 3 kW. Short circuit to L1.	Check HS 2. Check cabling.
913	HS 2 - Overload on L2	Current on L2 greater than 16 A	Check HS2 and replace HS if necessary.
914	HS 2 - Overload on L3	Current on L3 greater than 16 A	
915	HS 2 defective - L1 high-resistance	No current flowing through L1/L2/L3. L1/L2/L3 of HS 2 defective. Phase L1/L2/L3 interrupted.	Check L1/L2/L3. Check connections L1/L2/L3.
916	HS 2 defective - L2 high-resistance		
917	HS 2 defective - L3 high-resistance		
918	Relay 2 (phase L2) defective	Relay R2/R3 does not switch.	Replace Ohmpilot.
919	Relay 3 (phase L3) defective		
920	TS short circuit	Input resistance TS less than 200 ohms. No PT1000 TS connected. TS defective.	Check the cable and connections on the TS cable. Replace TS.
921	TS not connected or defective	No TS connected (input resistance greater than 2000 ohms). TS is activated (should be deactivated). TS cable defective. TS defective. No PT1000 TS connected.	Connect TS to device. Disable TS via the user interface (if no sensor is required). Check TS cable. Replace TS.

Status codes

922	60 °C for Legionella protection could not be reached within 24 hours.	FQ switched off/defective. (922 only). TS was mounted incorrectly. Heating system incorrectly dimensioned (too much hot water consumption, etc.) HS/TS defective.	Switch on FQ (only 922). Mount the TS above the HS (in the protective tube). Legionella prevention via the user interface. Replace HS/TS.
923	Minimum temperature could not be reached within 5 hours		
924	FQ could not reach minimum temperature within 5 hours.	FQ switched off/defective. FQ not connected to Ohmpilot. TS mounted incorrectly. Heating system incorrectly dimensioned (too much hot water consumption, etc.). TS defective.	Switch on FQ. Connect FQ to relay 1. Install TS above the heating register of the FQ. Check the minimum temperature setting. Replace TS.
925	Time not synchronized	Time not synchronized in the last 24 hours. Router has been switched off/reconfigured.	Check connection between Ohmpilot and inverter. Switch on the router. Check network settings.
926	No connection to the inverter	No connection between WR and Ohmpilot. WR switched off. The Ohmpilot also needs a connection to the WR at night. Router switched off/defective/reconfigured. Night shutdown activated on the inverter. Poor WLAN connection between inverter or Ohmpilot and router.	Check connections. Switch on WR. Update software. Switch the Ohmpilot and WR off and on again. Deactivate the night shutdown of the WR. On Fronius SnapINverters, set the night mode to "ON" on the display under Setup > Display Settings > Night Mode . Switch on the router. Better position the WLAN antenna. Check network settings.
927	Ohmpilot over-temperature	Ambient temperature too high (> 40 °C). The output of the heating element is too high. Ventilation slots are covered.	Install Ohmpilot in a cooler location. Use a heating element with a permissible output. Clear ventilation slots.

Status codes

928	Ohmpilot under-temperature	Ambient temperature too low (< 0 °C).	Install Ohmpilot in a warmer place. Installation outdoors is not permitted!
	Residual current circuit breaker triggers	Neutral conductor (N) and phase (L) mixed up.	Connect N and L correctly.
	Ohmpilot does not consume any surplus	Thermostat on heating element has switched off. Safety thermostat (STC) on the heating element has tripped.	Wait until the thermostat switches on again. Reset safety thermostat
	Ohmpilot consumes only part of the surplus power	Heating element output is lower than surplus power.	if necessary, select a larger heating element
	Power at the feed-in point is not always adjusted to 0	It takes a few seconds to compensate for load and generation fluctuations.	
	After switching on, the green LED continuously flashes 2 times	Thermostat on heating element has switched off. The heating element is not connected.	Turn up the thermostat briefly for the power measurement. Connect the heating element.
	After a power failure, the Ohmpilot no longer works	After a power failure, if the Ohmpilot does not receive an IP address after 40 s, the Ohmpilot automatically assigns the following fixed IP address: 169.254.0.180 (only valid if the Ohmpilot is connected to the router via WLAN).	Restart Ohmpilot so that the WLAN connection is re-established.

Technical data

Fronius Ohmpilot technical data

General data

Dimensions (height x width x depth)	350 mm x 280 mm x 110 mm
Weight	3.9 kg
Protection class	IP 54
Installation	Wall
Ambient temperature range	0 to 40 °C
Permissible humidity	0%-99% (non-condensing)
Cooling	Convection
Storage temperature	-40 to 70 °C
EMC emission class	B
Overvoltage category	3
Pollution degree	3

Input data

Frequency	50 Hz
Nominal voltage	230 V / 400 V
Max. input current	1x 16 A / 3x 16 A

Interfaces

Modbus RTU	RS 485, max. 300 m, shielded and twisted
LAN	Ethernet at least CAT5, shielded
WLAN	Standard IEEE 802.11 b/g/n
Temperature sensor	PT1000 (max. 30 m)

Output data

Analogue output 1-phase/3-phase	Continuously variable 0-3 / 0-9 kW
Analogue nominal current per phase	13 A
Analogue output short circuit current	16 A (max. 5 seconds)
Relay output max. current	L2 / L3 16 A (max. 5 seconds)
Multifunctional relay output	min. 15 V / 2 mA; max. 16 A (max. 5 seconds)
Efficiency during rated operation	at least 98%
Consumption during standby	typically 1.8 W

Tests/specifications

Tests/specifications

Tests/specifications per EN60730 Section 1 Table 7.2

6a	Construction	Electronic RS 2.5.5, independently mounted RS
19	Screwless terminals	2.10.6.1 type X mounting
24	Classification of the RS according to protection against electric shock, Section 6.8	Safety class I 6.8.3
29	Type of shutdown or open circuit for each circuit	Micro-interruption per 2.4.4.
30	PTI value of the insulation materials used for insulation	PTI 175 in accordance with 6.13.2
31a	Type of ground conductor connection	N in accordance with 7.4.3, grounding terminal in accordance with 9.1.1
39	Operating principle	Operating principle TYPE 1 in accordance with 2.6.1
40	Additional properties for operating principle	C in accordance with 6.4.3.3
51	Glow wire test temperatures (Sections 21.2.1, 21.2.2, 21.2.3, and 21.2.4)	Housing 550 °C, cable gland/strain-relief device 650 °C; category B in accordance with EN 60730-1:2000/A1:2004;
75	Rated surge voltage (Sections 2.1.12, 20.1)	In accordance with EN 61000-6-2:2005, EN 60730-1:2011, EN 301 489-1 (V1.9.2) Wire to wire Wire(s) to ground, signal and control lines: --- ± 1 kV DC grid inputs: ± 0.5 kV ± 0.5 kV AC grid inputs: ± 1 kV ± 2 kV
77	Temperature of the ball pressure test	In accordance with 21.2.1, 21.2.2, 21.2.3, and 21.2.4, case (housing): Ball pressure test 1: 102 °C Cable bushing (cable gland): Ball pressure test 2: 125 °C
80	Rated surge voltage for creepage distance or contact-gap	In accordance with EN 61000-6-2:2005, EN 60730-1:2011, EN 301 489-1 (V1.9.2) Wire to wire Wire(s) to ground Signal and control lines: --- ± 1 kV DC grid inputs: ± 0.5 kV ± 0.5 kV AC grid inputs: ± 1 kV ± 2 kV

Terms and conditions of warranty and disposal

Fronius manufacturer's warranty

Detailed, country-specific warranty conditions are available on the internet www.fronius.com/solar/garantie

Disposal

Waste electrical and electronic equipment must be collected separately and recycled in an environmentally sound manner in accordance with the European Directive and national law. Used equipment must be returned to the distributor or through a local authorized collection and disposal system. Proper disposal of the used device promotes sustainable recycling of resources and prevents negative effects on health and the environment.

Packaging materials

- Collect separately
 - Observe local regulations
 - Crush cardboard boxes
-

Applicable standards and directives

CE mark

The devices conform to all the requisite and relevant standards and guidelines that form part of the relevant EU directive, and are therefore permitted to display the CE mark.



fronius.com/en/solar-energy/installers-partners/products-solutions/monitoring-digital-tools

**MONITORING &
DIGITAL TOOLS**

Fronius International GmbH

Froniusstraße 1
4643 Pettenbach
Austria
contact@fronius.com
www.fronius.com

At www.fronius.com/contact you will find the contact details of all Fronius subsidiaries and Sales & Service Partners.