

# Operating Instructions

## Fronius Smart Meter IP

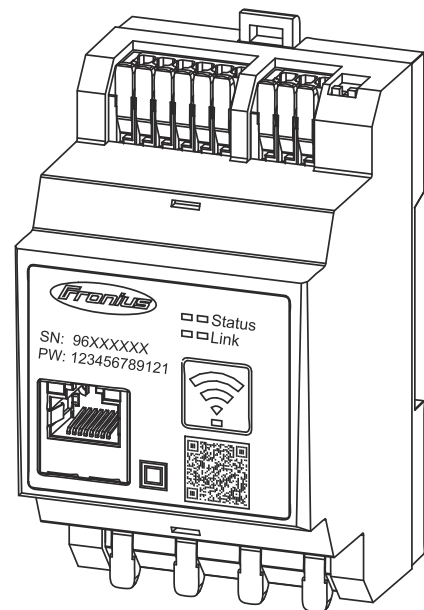

EN | Operating Instructions





# Contents

<b>Safety rules</b>	<b>5</b>
Safety rules.....	7
Explanation of safety notices .....	7
General.....	7
Environmental conditions.....	8
Qualified personnel.....	8
Copyright.....	8
Data security.....	8
<b>General information</b>	<b>9</b>
Fronius Smart Meter IP .....	11
Description of the device.....	11
Information on the device .....	11
Intended use.....	11
Scope of supply.....	12
Positioning.....	12
Measuring accuracy.....	13
Backup power mode.....	13
Control elements, connections and displays .....	14
Product overview .....	14
LED status indicators.....	14
<b>Installation</b>	<b>15</b>
Preparations.....	17
Choice of location.....	17
Installation.....	18
Checklist for installation.....	18
Installation.....	19
Protective circuit .....	19
Cabling.....	20
Suitable current transformers.....	21
Connecting the current transformers .....	22
Connecting the LAN .....	23
WLAN configuration .....	23
Connecting the Modbus RTU.....	23
Terminating resistors - Explanation of symbols .....	24
Setting the Modbus RTU terminating resistor.....	25
Terminating resistors .....	25
Setting the Modbus RTU BIAS .....	26
<b>Start-up</b>	<b>29</b>
Commissioning the Fronius Smart Meter IP .....	31
Opening the user interface with the QR code .....	31
Opening the user interface with the IP address .....	31
Software update.....	32
Fronius SnapINverter.....	33
General.....	33
Connecting to the Fronius Datamanager 2.0.....	33
Configuring the primary meter .....	33
Configuring secondary meters.....	34
Modbus participants - Fronius SnapINverter.....	34
Multi-meter system - Explanation of symbols.....	35
Multi-meter system - Fronius SnapINverter.....	36
Fronius GEN24 inverter.....	38
General.....	38
Installation using the web browser .....	38

Configuring the primary meter .....	39
Configuring secondary meters .....	39
Modbus participants - Fronius GEN24.....	40
Multi-meter system - Explanation of symbols.....	41
Multi-meter system - Fronius GEN24 inverter .....	42
<b>User interface</b> .....	<b>45</b>
Overview .....	47
Overview .....	47
Settings.....	48
Advanced settings.....	48
Restoring the factory settings.....	49
Changing the input current of the current transformers.....	49
<b>Appendix</b> .....	<b>51</b>
Care, maintenance and disposal.....	53
Maintenance.....	53
Cleaning.....	53
Disposal.....	53
Fronius manufacturer's warranty.....	53
Technical data.....	54
Technical data.....	54

# **Safety rules**



# Safety rules

---

## Explanation of safety notices

### **DANGER!**

**Indicates immediate danger.**

- ▶ If not avoided, death or serious injury will result.
- 

### **WARNING!**

**Indicates a potentially hazardous situation.**

- ▶ If not avoided, death or serious injury may result.
- 

### **CAUTION!**

**Indicates a situation where damage or injury could occur.**

- ▶ If not avoided, minor injury and/or damage to property may result.
- 

### **NOTE!**

**Indicates a risk of flawed results and possible damage to the equipment.**

---

## General

The device has been manufactured in line with the state of the art and according to recognized safety standards. If used incorrectly or misused, however, it can cause:

- Injury or death to the operator or a third party
  - Damage to the device and other material assets belonging to the operating company.
- 

All personnel involved in commissioning, maintenance, and servicing of the device must:

- Be suitably qualified
  - Have knowledge of and experience in dealing with electrical installations and
  - Have fully read and precisely followed these Operating Instructions
- 

The Operating Instructions must always be at hand wherever the device is being used. In addition to the Operating Instructions, attention must also be paid to any generally applicable and local regulations regarding accident prevention and environmental protection.

---

All safety and danger notices on the device:

- Must be kept in a legible state
  - Must not be damaged
  - Must not be removed
  - Must not be covered, pasted or painted over
- 

The terminals can reach high temperatures.

Only operate the device when all protection devices are fully functional. If the protection devices are not fully functional, there is a danger of:

- Injury or death to the operator or a third party
  - Damage to the device and other material assets belonging to the operating company
-

Any safety devices that are not fully functional must be repaired by an authorised specialist before the device is switched on.

---

Never bypass or disable protection devices.

---

For the location of the safety and danger notices on the device, refer to the section headed "General remarks" in the Operating Instructions for the device.

---

Any equipment malfunctions which might impair safety must be remedied before the device is turned on.

---

**This is for your personal safety!**

---

---

**Environmental conditions**

Operation or storage of the device outside the stipulated area will be deemed as not in accordance with the intended purpose. The manufacturer accepts no liability for any damage resulting from improper use.

---

**Qualified personnel**

The servicing information contained in these operating instructions is intended only for the use of qualified service engineers. An electric shock can be fatal. Do not carry out any actions other than those described in the documentation. This also applies to qualified personnel.

---

All cables and leads must be secured, undamaged, insulated and adequately dimensioned. Loose connections, scorched, damaged or inadequately dimensioned cables and leads must be immediately repaired by authorised personnel.

---

Maintenance and repair work must only be carried out by an authorised specialist.

---

It is impossible to guarantee that bought-in parts are designed and manufactured to meet the demands made on them, or that they satisfy safety requirements. Use only original spare parts (also applies to standard parts).

---

Do not carry out any alterations, installations, or modifications to the device without first obtaining the manufacturer's permission.

---

Components that are not in perfect condition must be changed immediately.

---

**Copyright**

Copyright of these operating instructions remains with the manufacturer.

---

Text and illustrations were accurate at the time of printing, subject to change. We are grateful for suggestions for improvement and information regarding any discrepancies in the operating instructions.

---

**Data security**

With regard to data security, the user is responsible for:

- backing up any changes made to the factory settings
- saving and retaining personal settings



# **General information**



# Fronius Smart Meter IP

## Description of the device

The Fronius Smart Meter IP is a bidirectional electricity meter which optimises self-consumption and records a household's load curve. In conjunction with a Fronius inverter or Fronius Datamanager 2.0 and a Fronius data interface, the Fronius Smart Meter IP provides an overview of a user's own power consumption.

The meter measures the energy flow to the loads or to the public grid and forwards the information via the Modbus RTU/RS485- or TCP interface (LAN/WLAN) to the Fronius inverter or the Fronius Datamanager 2.0.

## Information on the device

Technical data, markings and safety symbols are located on the Fronius Smart Meter IP. These must NOT be removed or painted over. They warn against incorrect operation which can lead to serious injury and damage.

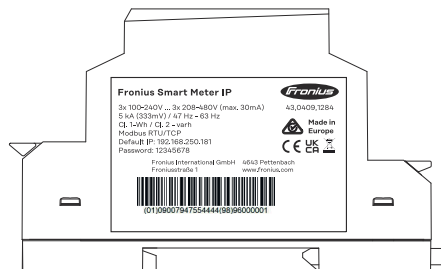

### Symbols on the rating plate:



CE mark – confirms compliance with applicable EU directives and regulations. The product has been tested by a specific notified body.



WEEE mark – waste electrical and electronic equipment must be collected separately and recycled in an environmentally sound manner in accordance with the European Directive and national law.



UKCA mark – confirms compliance with applicable UK directives and regulations.



RCM mark – tested in accordance with the requirements of Australia and New Zealand.

## Intended use

The Fronius Smart Meter IP is a fixed piece of equipment for public grids of TN/TT systems and may only be used to measure loads and self-consumption. The Fronius Smart Meter IP is required for systems with a battery storage system and/or a Fronius Ohmpilot installed for communication between the individual components.

The installation is carried out on an indoor DIN rail with corresponding back-up fuses, which are adapted to the cable cross-sections of the copper conductors and to the maximum current of the meter. The Fronius Smart Meter IP must only be operated in accordance with the specifications in the enclosed documentation and in accordance with local laws, regulations, provisions, standards and within

the limits of technical possibilities. Any use of the product other than as described in the intended use shall be deemed to be not in accordance with the intended purpose.

The available documentation forms part of the product and must be read, observed and kept in good condition. It must also be accessible at all times at the place of installation. Fronius International GmbH assumes no responsibility for compliance with or non-compliance with these laws or regulations in connection with the installation of the product.

---

### Scope of supply

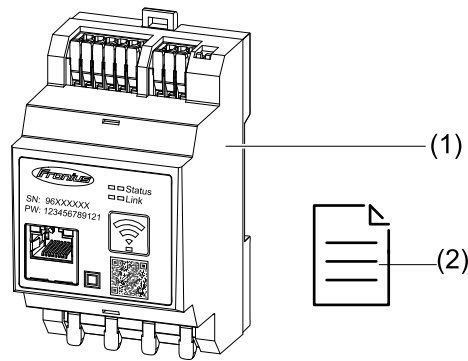

- (1) Fronius Smart Meter IP
- (2) Quick Start Guide

---

### Positioning

The Smart Meter can be installed in the following positions in the system:

#### Positioning at the feed-in point

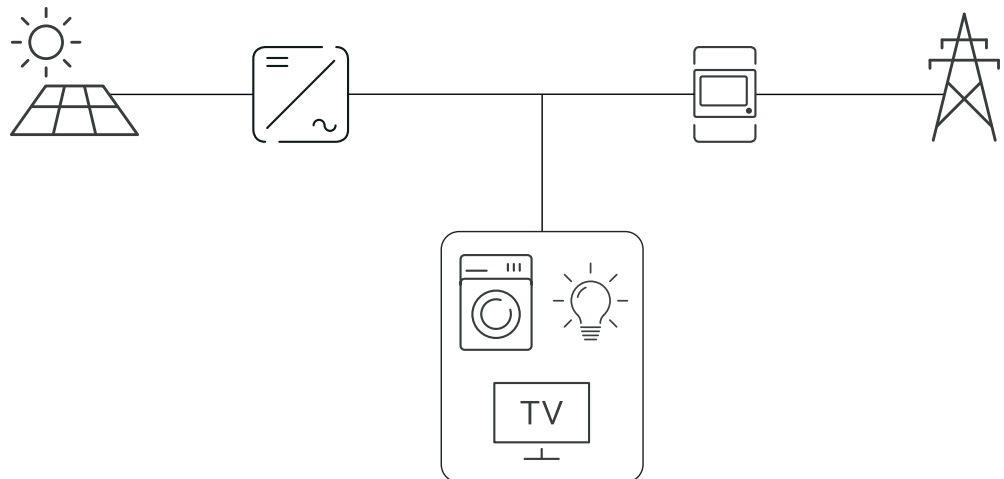

## Positioning at the consumption point

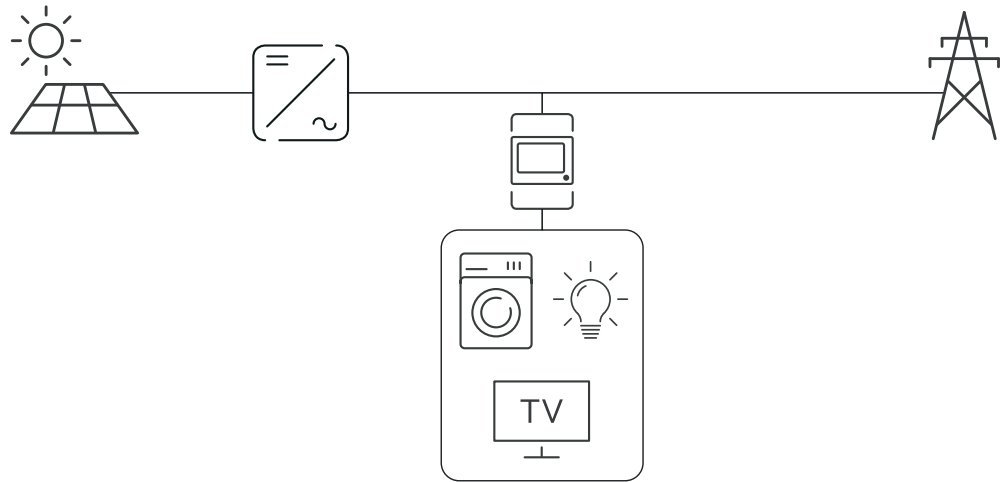

---

### Measuring accuracy

The Fronius Smart Meter IP has accuracy class 1 when measuring active energy (EN IEC 62053-21) in the voltage ranges 208 - 480 VLL and 100 - 240 VLN. For further details see [Technical data](#) on page 54.

---

### Backup power mode

The Fronius Smart Meter IP is backup power capable with Modbus RTU/TCP data cabling. When connecting via Modbus TCP, make sure that the grid reset time is increased by starting the network. Fronius recommends a Modbus RTU connection.

# Control elements, connections and displays

## Product overview

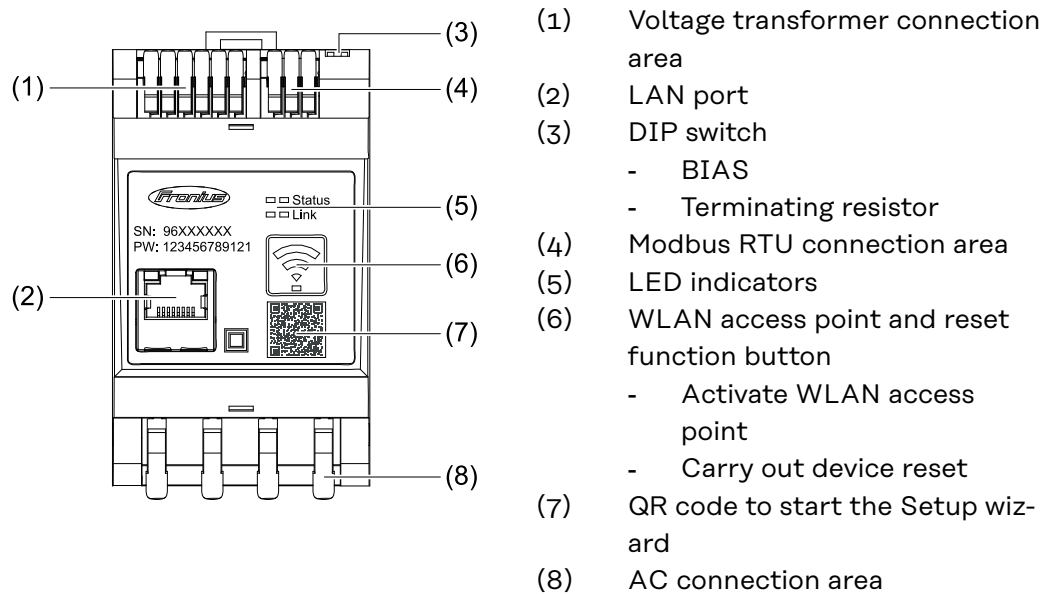

- (1) Voltage transformer connection area
- (2) LAN port
- (3) DIP switch
  - BIAS
  - Terminating resistor
- (4) Modbus RTU connection area
- (5) LED indicators
- (6) WLAN access point and reset function button
  - Activate WLAN access point
  - Carry out device reset
- (7) QR code to start the Setup wizard
- (8) AC connection area

## LED status indicators

The LED status indicators show the operating status and data connection of the Fronius Smart Meter IP.

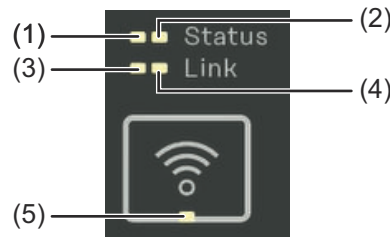

- (1) **Status 1 LED**  
Lights up green: Ready for operation
- (2) **Status 2 LED**  
Lights up: Device starting up / restarting

- (3) **Link 1 LED**  
Steady green: Data connection established with the network
- (4) **Link 2 LED**  
Lights up red: No data connection  
Flashing red: Open WLAN access point
- (5) **WLAN LED**  
Flashing green: WLAN connection is being established  
Lights up green: WLAN connection is active

# Installation





# Preparations

---

## Choice of location

Please note the following criteria when choosing a location for the Smart Meter:

Only install on a solid, non-flammable surface.

When installing the Smart Meter in a switch cabinet or similar enclosure, make sure that it is of the appropriate safety class and that the hot air that develops will be dissipated by forced-air ventilation.



The Smart Meter is suitable for indoor installation.

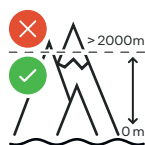

The Smart Meter must not be installed or used at altitudes above 2000 m.

---

# Installation

---

## Checklist for installation

For installation information, see the following chapters:

- 1 Switch off the power supply before connecting to the public grid.
- 2 Mount the Fronius Smart Meter IP (see [Installation](#) on page 19).
- 3 Connect the automatic circuit breaker (see [Protective circuit](#) on page 19).
- 4 Connect the mains voltage inputs to the Fronius Smart Meter IP (see [Cabling](#) on page 20).
- 5 Note down the nominal current of the current transformer for each meter. These values are required during commissioning.
- 6 Connect the current transformers and Fronius Smart Meter IP (see [Suitable current transformers](#) on page 21).
- 7 Mount the current transformers on the conductors. Make sure that the current transformers are pointing in the correct direction. An arrow either points to the connected load or the outlet to the public grid (see [Connecting the current transformers](#) on page 22 or the current transformer user information).
- 8 Make sure that the current transformer phases match the mains voltage phases (see [Connecting the current transformers](#) on page 22).
- 9 Establish the data connection of the Fronius Smart Meter IP. The data connection can be established in three different ways:
  - Modbus RTU (recommended for backup power operation), see 23 on page 23.
  - LAN, see [Connecting the LAN](#) on page 23.
  - WLAN, see [WLAN configuration](#) on page 23.
- 10 With Modbus RTU connection: Set terminating resistor (see [Setting the Modbus RTU terminating resistor](#) on page 25).
- 11 With Modbus RTU connection: Set the BIAS switch (see [Setting the Modbus RTU BIAS](#) on page 26).
- 12 Check the single conductors/plug connections on the Smart Meter IP are secure.
- 13 Switch on the power supply to the Fronius Smart Meter IP.
- 14 Check the firmware version of the Fronius system monitoring (see "[Technical data](#)"). To ensure compatibility between the inverter and the Fronius Smart Meter IP, the software must always be kept up to date. The update can be started via the user interface of the inverter or using Fronius Solar.web (see "[Advanced settings](#)").
- 15 Configure the Fronius Smart Meter IP and put it into operation (see [Start-up](#) on page 29).

## Installation

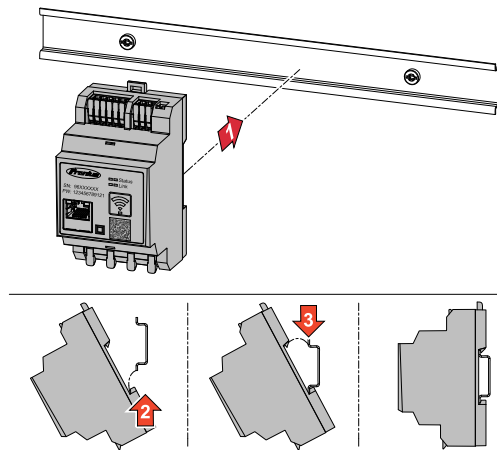

The Fronius Smart Meter IP can be mounted on a 35 mm DIN rail. The housing comprises 3 modules according to DIN 43880.

## Protective circuit

The Fronius Smart Meter IP is a hard-wired device and requires a disconnecting device (automatic circuit breaker).

The Fronius Smart Meter IP consumes 30 mA, the nominal capacity of the disconnecting devices and the overcurrent protection is determined by the conductor cross-sections, the mains voltage and the required breaking capacity.

- The disconnecting devices must be mounted in the same enclosure (e.g. switch cabinet) as the Fronius Smart Meter IP.
- The disconnecting devices must satisfy the requirements of IEC 60947-1 and IEC 60947-3, as well as all national and local regulations for electrical systems.
- To monitor multiple mains voltages, use connected automatic circuit breakers.

### NOTE!

#### Disconnecting device for the mains terminals

- The automatic circuit breaker must protect the mains terminals marked L1, L2 and L3. In rare cases, the neutral conductor has a disconnecting device, which must interrupt both neutral and non-earthed cables concurrently.

## Cabling

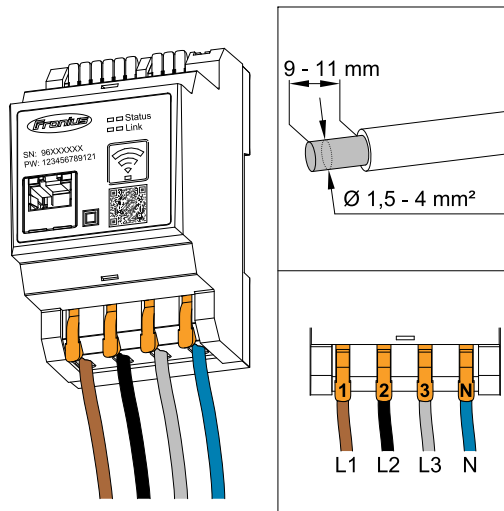

### **⚠ WARNING!**

#### **Danger from live mains voltage inputs**

An electric shock can be fatal.

- ▶ Switch off the power supply before connecting the mains voltage inputs.

Permissible conductor cross-section of AC terminals:

- Wire: 1.5 - 4 mm<sup>2</sup>

Each live conductor must be connected to the AC terminals as shown in the figures below.

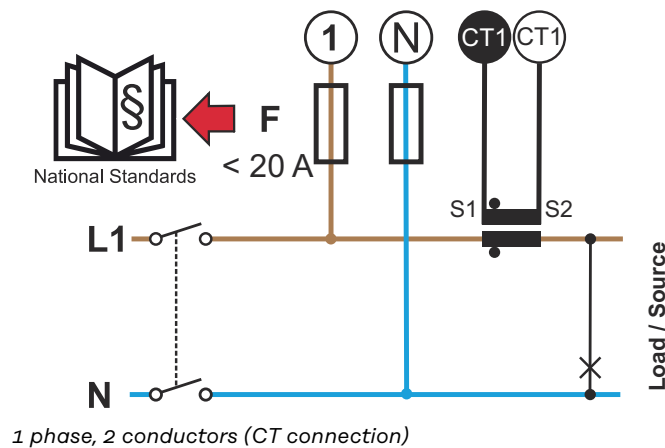
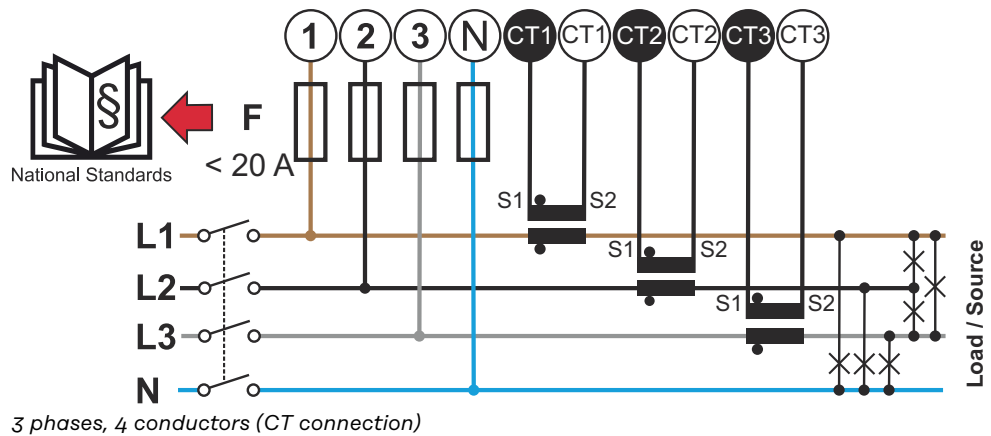

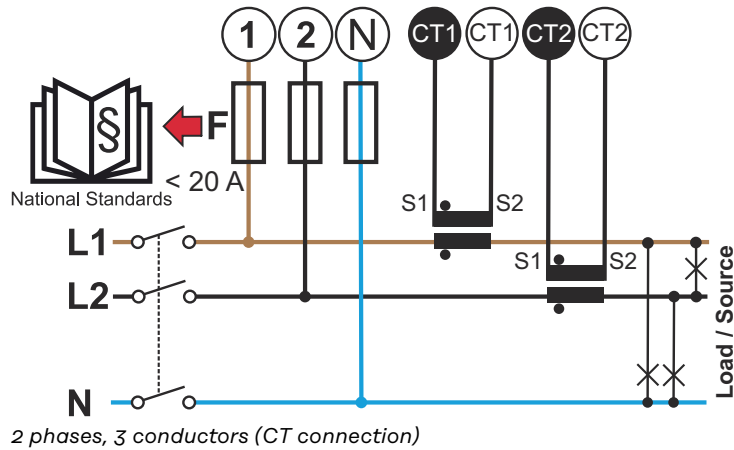

### Suitable current transformers

It is recommended to use Fronius CT current transformers (item numbers 41,0010,0104 / 41,0010,0105 / 41,0010,0232). To ensure smooth operation of the Fronius Smart Meter IP and accurate measurement results, all connected current transformers must meet these requirements:

- The current transformer must generate 333 mV at nominal current. The nominal current of the current transformers is listed in the data sheet for the current transformer.
- Do not use current transformers with 1 ampere or 5 ampere output current.
- Observe the maximum input current according to the data sheets of the current transformers.
- Do not use Rogowski coils for measurement purposes.
- Hinged and rigid current transformers can be mounted. Rigid current transformers often have better power and accuracy values. Hinged current transformers have a split core and can be opened for mounting on the conductor and installed in a system without interrupting the voltage.

### CAUTION!

#### Risk of electric shock due to unintentional opening of hinged current transformers

This can result in severe injury and damage to property.

- ▶ Switch off the current when working on the current transformers.
- ▶ Attach a plastic cable tie to the current transformer to prevent unintentional opening.

## Connecting the current transformers

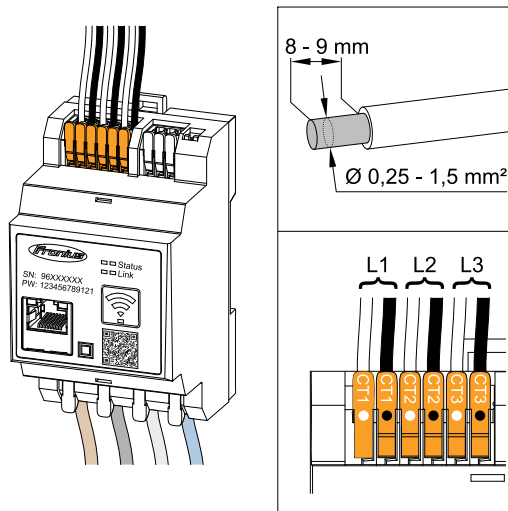

- 1 Make sure that the current transformers match the live phases. Make sure that current transformer L1 measures the current on the same phase that is monitored by voltage input L1. The same applies for phases L2 and L3. This is the only way to display correct measured values.
- 2 Make sure that the current transformers are pointing in the correct direction.

### NOTE!

#### Observe direction information when installing the current transformers

Negative power values occur when the current transformers are connected incorrectly.

- ▶ Observe the data sheet and the marking on the current transformer (arrow indicates the direction to the load or to the public grid)
- ▶ Check the correct position of the black and white cable.

- 3 Note down the nominal current of the current transformer for each meter. These values will be required for commissioning.
- 4 Attach the current transformers to the conductor to be measured and connect the current transformer cables to the Fronius Smart Meter IP.

### ⚠ WARNING!

#### Danger from mains voltage

An electric shock can be fatal.

- ▶ Switch off the power supply before disconnecting live conductors.

- 5 Connect the current transformers to the terminals CT1 (white / black), CT2 and CT3. Excessively long cables can be shortened accordingly. Observe the sequence in which the phases are connected.
- 6 Route the mains conductors through the current transformers (see [Cabling](#)).

### NOTE!

#### Cable length of the current transformers

Cables that are too long can have a negative effect on the measuring accuracy.

- ▶ If a cable extension is necessary, use a shielded 0.34 to 1.5 mm<sup>2</sup> (AWG 22-16) CAT 5 STP (Shielded Twisted Pair) cable rated for 300 V or 600 V (higher than the operating voltage).

## NOTE!

### Unusual measured values on unused phases

- ▶ If unusual measured values occur on unused phases, bypass the unused current transformer inputs.
- ▶ To do so, for each unused current transformer, connect the terminal marked with a white dot to the terminal marked with a black dot using a short cable.

### Connecting the LAN

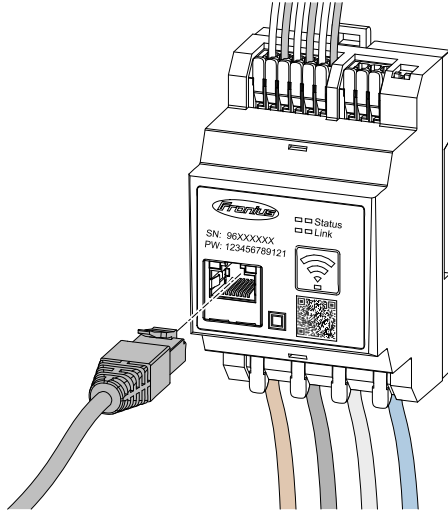

Observe the following instructions:

- Use a shielded data cable of type CAT 5 STP (Shielded Twisted Pair) or higher.
- If the data lines are close to the mains cabling, use cables that are designed for 300 to 600 V (never less than the operating voltage).
- Use double-insulated or sheathed data cables when they are close to bare conductors.
- The use of a static IP address is recommended.

### WLAN configuration

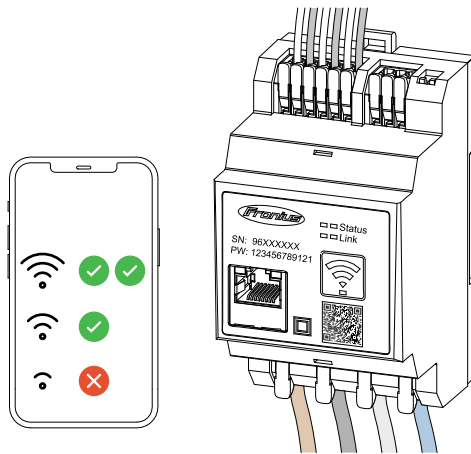

### IMPORTANT!

Ensure sufficient WLAN signal strength at the installation site. If the signal strength is low, a WLAN booster must be installed, for example.

The use of a static IP address is recommended.

### Connecting the Modbus RTU

Connect the data communication connections of the Fronius Smart Meter IP to the Modbus interface of the Fronius inverter using a CAT 5 STP (Shielded Twisted Pair) or higher data cable.

The Fronius Smart Meter IP can also be connected to the network (LAN / WLAN). This allows software updates to be carried out.

Standard Modbus address & TCP port:

- Address: 1
- TCP port: 502

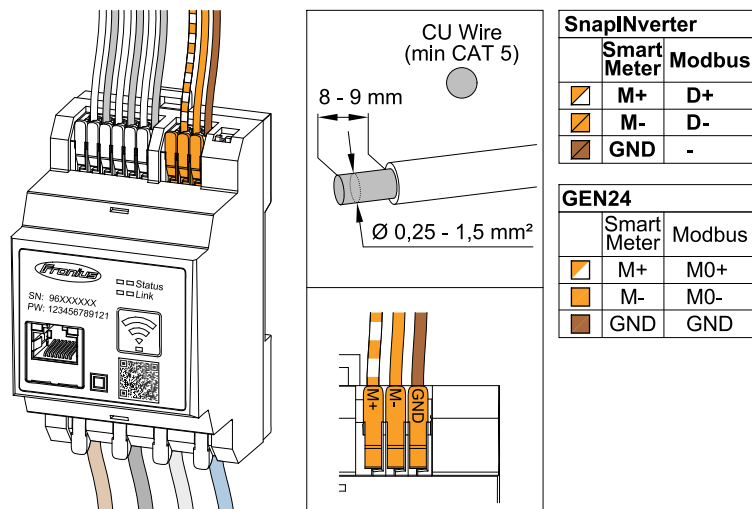

To avoid interference, the terminating resistor must be used (see chapter [Setting the Modbus RTU terminating resistor](#) on page 25).

If a battery is installed in the system, the BIAS switch must be set (see chapter [Setting the Modbus RTU BIAS](#) on page 26).

Further settings are necessary on the user interface of the inverter and the Fronius Smart Meter IP (see [Advanced settings](#)).

### IMPORTANT!

A loose wire can disable an entire area of the network. The data communication connections of the Fronius Smart Meter IP are electrically isolated from hazardous voltages.

### Further information for commissioning

Observe the following information on connecting the data communication cable to the inverter.

- Use a shielded CAT 5 STP (Shielded Twisted Pair) or higher data cable to avoid interference.
- Use a mutual twisted cable pair for corresponding data lines (D+/D-, M1+/M1-).
- If the data lines are laid close to the mains cabling, cables or wires that are designed for 300 to 600 V must be used (never less than the operating voltage).
- Use double-insulated or sheathed data lines when they are close to bare conductors.
- Two wires can be installed in each terminal; the wires are twisted first, inserted into the terminal and tightened.

### Terminating resistors - Explanation of symbols



#### Inverter in the system

e.g. Fronius Symo



#### Meter - Fronius Smart Meter IP

Terminating resistor is set to ON with the DIP switch.



#### Fronius or third-party device, connection via Modbus TRU

e.g. Fronius Ohmpilot, battery, etc.





**Terminating resistor**  
R 120 Ohm

### Setting the Modbus RTU terminating resistor

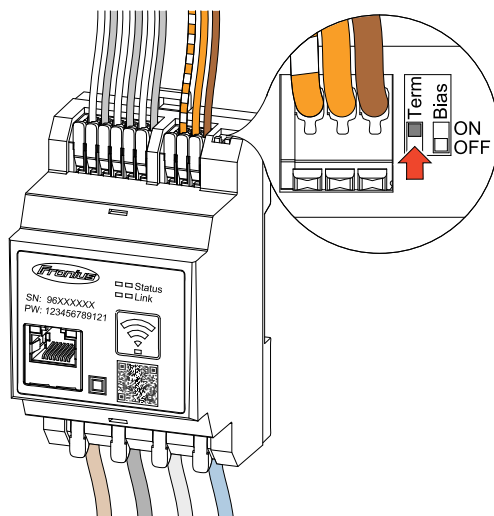

The terminating resistor is integrated in the Fronius Smart Meter IP and is set by a switch.

For information on whether the terminating resistor must be set or not, see chapter [Terminating resistors](#) on page 25.

### Terminating resistors

Due to interference, it is recommended that terminating resistors are used as illustrated below to ensure proper functioning.

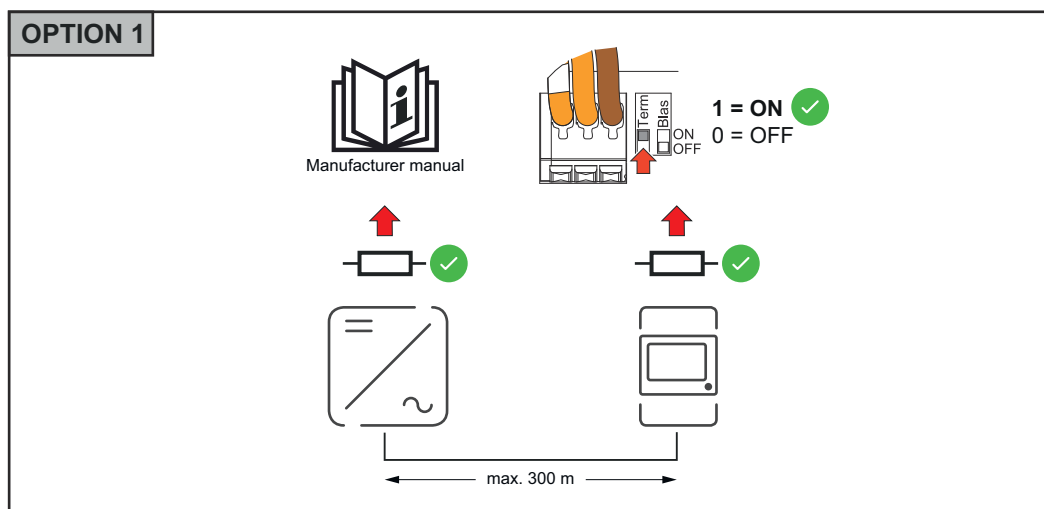

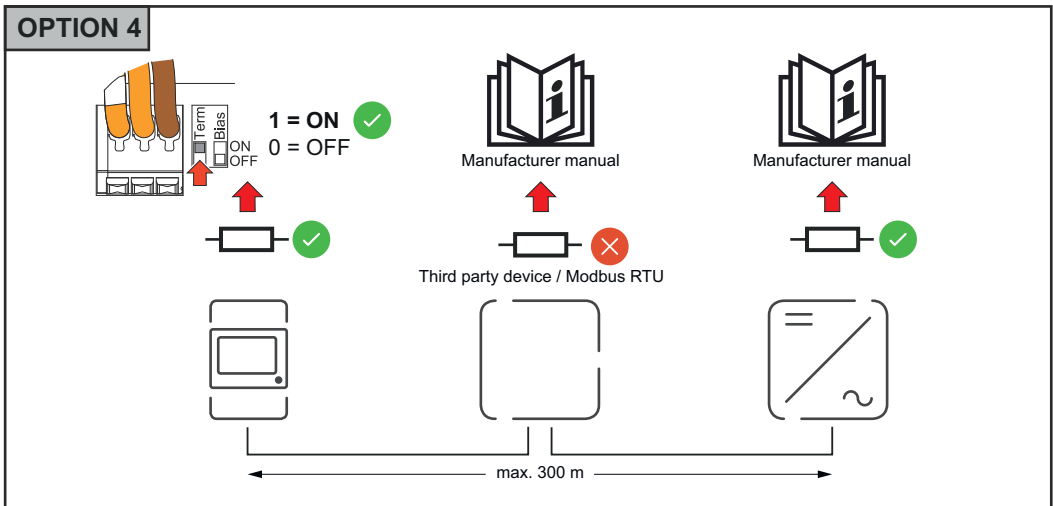
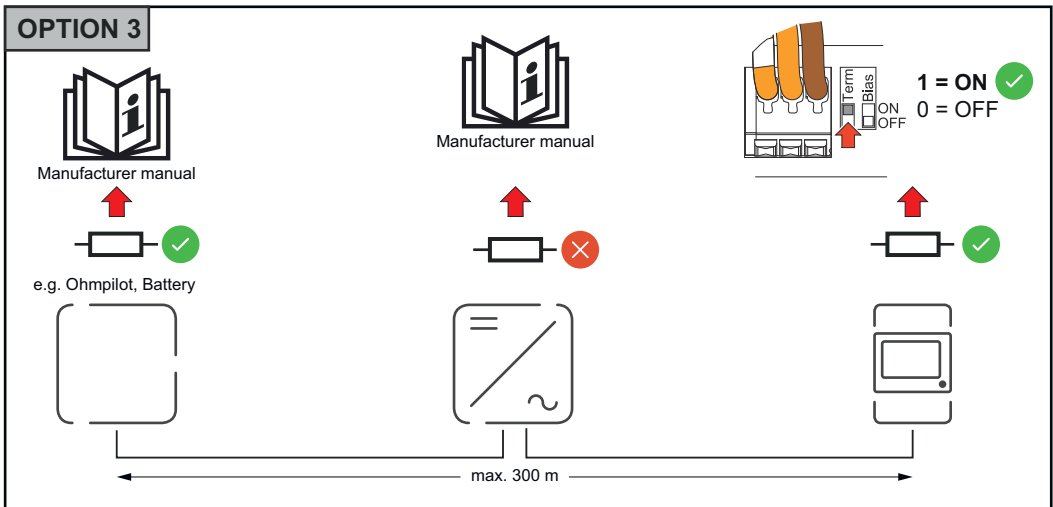
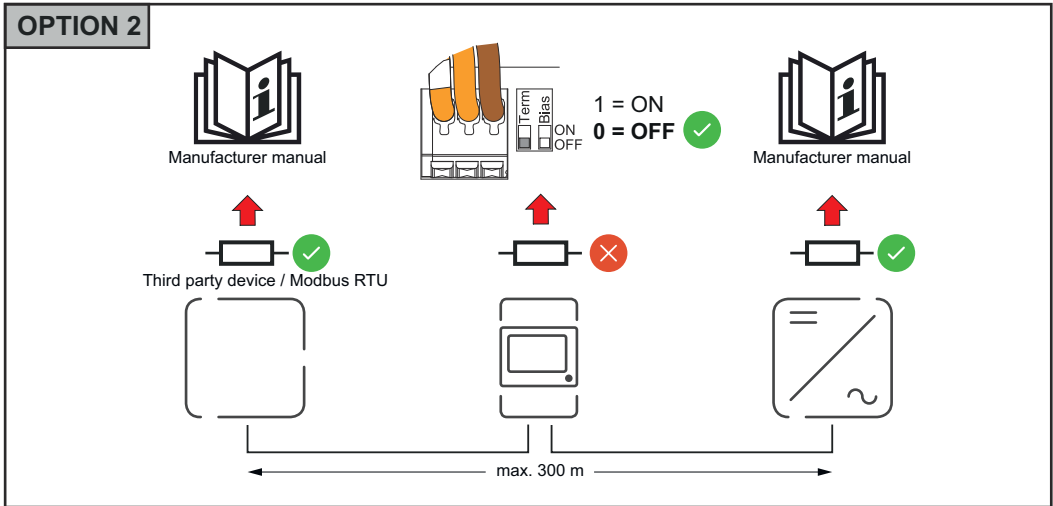

**Setting the Modbus RTU BIAS**

If the Smart Meter is connected to the same Modbus interface (MBO or MB1) as the battery, the BIAS switch must be set to ON.

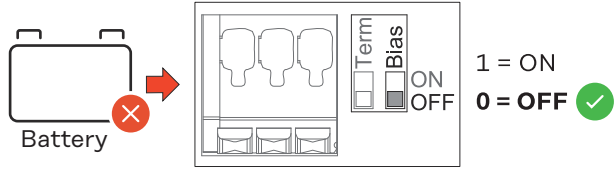
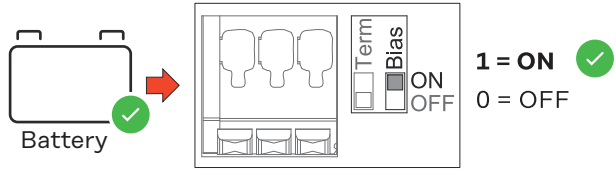



# Start-up



# Commissioning the Fronius Smart Meter IP

## Opening the user interface with the QR code

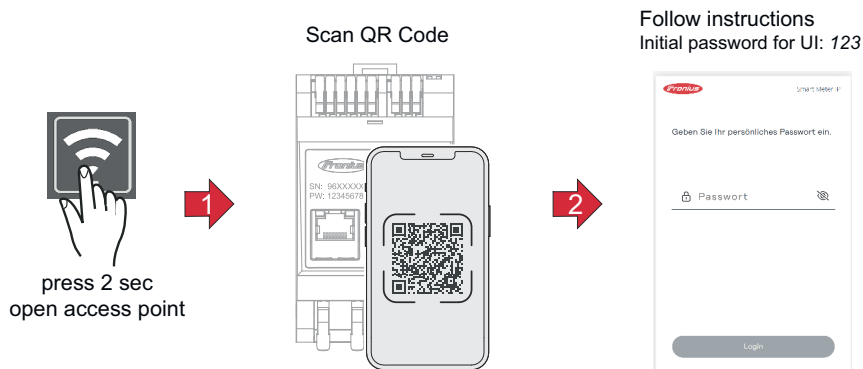

- 1 Press the access point button for two seconds. Link 2 LED flashes red.
- 2 Scan the QR code on the front of the device.
- 3 Enter the initial password and press **Login**.
- 4 Follow the instructions in the installation wizard and complete the installation.
- 5 Add the Smart Meter IP on the user interface of the inverter (see Commissioning GEN24 / SnapINverter).

## Opening the user interface with the IP address

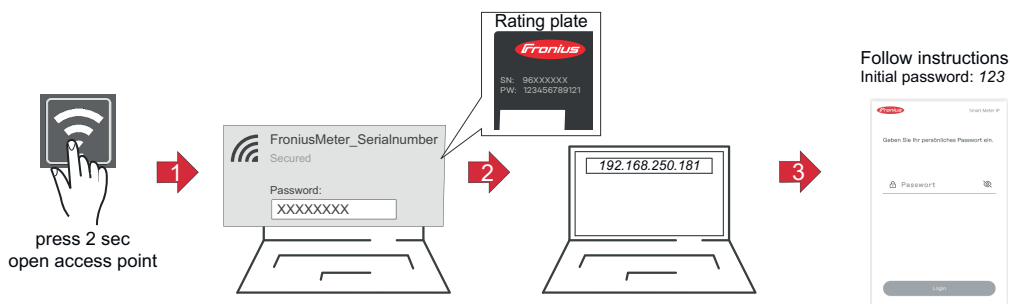

- 1 Press the access point button for two seconds. Link 2 LED flashes red.
- 2 Establish a connection from the end device to the access point  
SSID = FroniusMeter\_XXXXX (XXXX = serial number)  
Password = see Smart Meter (PW)
- 3 In the browser address bar, enter and confirm the IP address 192.168.250.181. The installation wizard is opened.
- 4 Follow the installation wizard in the individual sections and complete the installation.
- 5 Add the Smart Meter IP on the user interface of the inverter (see Commissioning GEN24 / SnapINverter).

---

**Software update** It is recommended to activate the **Automatic Updates** function during commissioning. The Fronius Smart Meter IP checks for available updates daily and automatically installs them between midnight and 6 o'clock. A precise time can be set.

If this function is not activated, software updates can also be searched for and started manually on the user interface of the device.

The software of the Fronius Smart Meter IP is compatible with the following software versions of connected Fronius components:

- Fronius GEN24 & Tauro: full compatibility from version 1.24.1
- Fronius SnapINverter (Fronius Datamanager 2.0): full compatibility from version 3.28.1
- Fronius Symo Hybrid: full compatibility from version 1.28.1
- Fronius Wattpilot: full compatibility from version 1.9.29



# Fronius SnapINverter

---

## General

**IMPORTANT!** Settings under the "**Meter**" menu item are only to be made by trained and qualified personnel!

The service password must be entered in order to access the "**Meter**" menu item.

The meter is selected in the **Fronius Smart Meter** menu item. The Fronius Datamanager 2.0 automatically identifies the meter type.

A primary meter and several secondary meters can be selected. The primary meter needs to be configured first before a secondary meter can be selected.

The Fronius Smart Meter IP can be connected with Modbus TCP or Modbus RTU.

---

## Connecting to the Fronius Datamanager 2.0

### Access point:

Activate the WiFi access point of the inverter:

- 1 Select the **Setup** menu on the inverter display.
- 2 Navigate to **WiFi Access Point**.
  - ✓ *Network (SS) and password (PW) are displayed.*
- 3 Activate the **WiFi Access Point** with the Enter ↵ key.

Establish the connection from the inverter's WiFi access point to the PC:

- 1 Establish the connection to the inverter in the network settings (the inverter is displayed with the name "Fronius\_240.XXXXXX").
- 2 Enter password from the inverter display and confirm.
- 3 In the browser address bar, enter the IP address <http://192.168.250.181> and confirm.

✓ *The Fronius Datamanager 2.0 start page is displayed.*

---

### LAN:

- 1 Connect the Fronius Datamanager 2.0 and computer with a LAN cable.
  - 2 Place the Fronius Datamanager 2.0 IP switch in the "A" position.
  - 3 In the browser address bar, enter the IP address <http://169.254.0.180> and confirm.
- 

## Configuring the primary meter

- 1 Open the Fronius Datamanager 2.0 user interface.
  - Open a browser.
  - In the address bar of the browser, enter the IP address (for WLAN: 192.168.250.181, for LAN: 169.254.0.180) or the host and domain name of the Fronius Datamanager 2.0 and confirm.
  - The Fronius Datamanager 2.0 user interface is displayed.
- 2 Click the **Settings** button.
- 3 Log in to the login area with the **service** user and the service password.
- 4 Call up the **Meter** menu area.
- 5 Select the **Fronius Smart Meter (RTU)** or **Fronius Smart Meter (TCP)** primary meter from the drop-down list.

- 6 Click the **Settings** button.
- 7 If using **Fronius Smart Meter (TCP)**, enter the IP address of the Fronius Smart Meter IP. A static IP address is recommended for the Fronius Smart Meter.
- 8 Set the position of the meter (**feed-in point** or **consumption point**). For more information on the position of the Fronius Smart Meter IP, see **Positioning** on page 12.
- 9 Click the **Ok** button when the **OK** status is displayed. If the **Timeout** status is displayed, try again.
- 10 Click the   button to save the settings.

The Fronius Smart Meter IP is configured as the primary meter.

The **Current general view** menu area displays the power of the PV modules, self-consumption, the energy fed into the grid and the battery charge (if available).

### Configuring secondary meters

- 1 Log in to the Smart Meter IP (IP WLAN: 192.168.250.181) and change the Modbus address accordingly under **Advanced settings > Data interface > Modbus address** accordingly (1 = primary meter)  
**IMPORTANT**  
A Modbus address can only be assigned once.
- 2 Open the Fronius Datamanager 2.0 user interface.
  - Open a browser.
  - In the address bar of the browser, enter the IP address (for WLAN: 192.168.250.181, for LAN: 169.254.0.180) or the host and domain name of the Fronius Datamanager 2.0 and confirm.
  - The Fronius Datamanager 2.0 user interface is displayed.
- 3 Click the **Settings** button.
- 4 Log in to the login area with the **service** user and the service password.
- 5 Call up the **Meter** menu area.
- 6 Select the secondary meter from the drop-down list.
- 7 Click the **Add** button.
- 8 Enter the name of the secondary meter in the **Name** input field.
- 9 Enter the previously assigned address in the **Modbus address** input field. The secondary meter address must match the Modbus address set on the Smart Meter IP.
- 10 Add meter description.
- 11 Click the   button to save the settings.

The Fronius Smart Meter IP is configured as a secondary meter.

### Modbus participants - Fronius SnapINverter

**Modbus RTU:** A maximum of 4 Modbus participants can be connected to the Modbus terminal.

**Modbus TCP:** A maximum of 7 secondary meters can be used in the system.

#### **IMPORTANT!**

Only one primary meter, one battery and one Ohmpilot can be connected per inverter. Due to the high data transfer of the battery, the battery occupies 2 participants.

**Example:**

Input	Battery	Fronius Ohmpilot	Number of primary meters	Number of secondary meters
<b>Modbus</b>	✓	✓	1	0
	✓	✗	1	1
	✗	✓	1	2
	✗	✗	1	3

**Multi-meter system - Explanation of symbols**



**Grid**

Supplies the loads in the system if insufficient power is being generated by the PV modules or supplied by the battery.



**Inverter in the system**

e.g. Fronius Primo, Fronius Symo, etc.



**Utility meter**

Measures the measurement data relevant for billing amounts of energy (in particular kilowatt hours of energy sourced from the grid and energy fed into the grid). Based on the relevant billing data, the electricity retailer will invoice the energy sourced from the grid and the purchaser of the surplus energy will reimburse the energy fed into the grid.



**Primary meter**

Records the system's load curve and provides measurement data for energy profiling in Fronius Solar.web. The primary meter also controls the dynamic feed-in control.



**Secondary meter**

Records the load curve of individual loads (e.g. washing machine, lamps, TV, heat pump, etc.) in the consumption branch and provides measurement data for energy profiling in Fronius Solar.web.



**Producer meter**

Records the load curve of individual producers (e.g. wind power plant) in the consumption branch and provides measurement data for energy profiling in Fronius Solar.web.



**Modbus RTU secondary device**

e.g. Fronius Ohmpilot, battery, etc.



**Loads in the system**

e.g. washing machine, lamps, TV, etc.



**Additional loads in the system**

e.g. heat pump



### Additional producers in the system

e.g. wind power plant



### Terminating resistor

R 120 Ohm

## Multi-meter system - Fronius SnapINverter

If several Fronius Smart Meters are installed, a separate address must be set for each one (see [Advanced settings](#) on page 48). The primary meter is always assigned address 1. All the other meters are numbered consecutively with the address range from 2 to 14. Different Fronius Smart Meter power categories can be used in combination.

### IMPORTANT!

Max. 3 secondary meters may be used in the system. To avoid interference, it is recommended to install the terminating resistors according to chapter [Terminating resistors](#) on page 25.

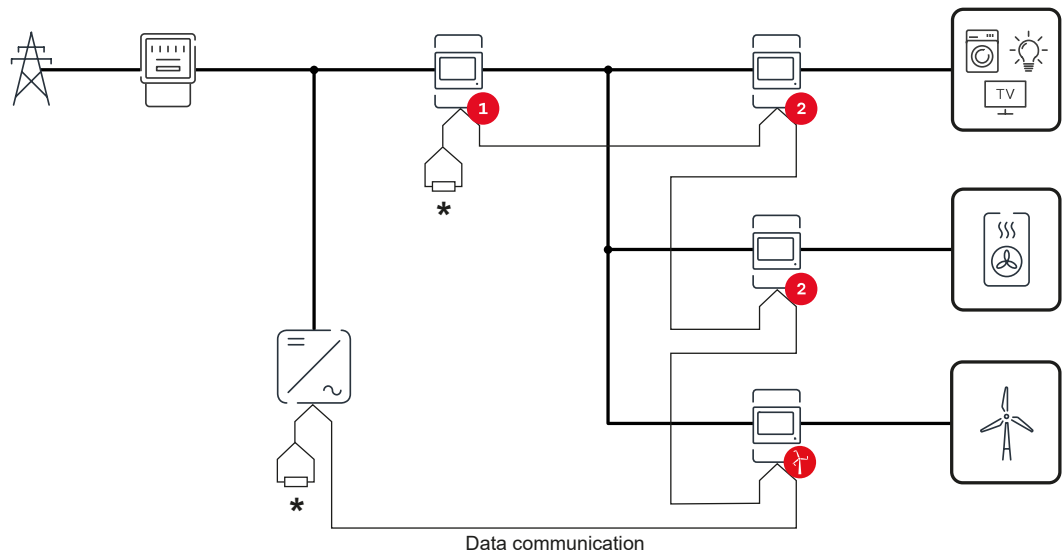

Location of the primary meter in the consumption branch. \*Terminating resistor R 120 Ohm

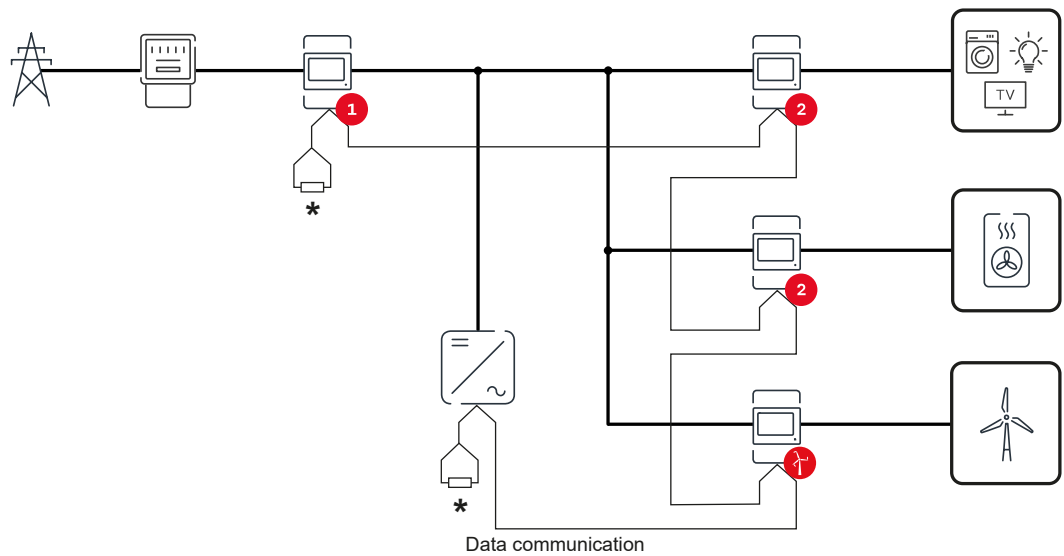

Location of the primary meter at the feed-in point. \*Terminating resistor R 120 Ohm

**The following must be observed in a multi-meter system:**

- Only assign each Modbus address once.
- Terminating resistors must be positioned individually for each channel.

# Fronius GEN24 inverter

## General

**IMPORTANT!** Settings under the **Device configuration** menu item are only to be made by trained and qualified personnel!

The technician password must be entered in order to access the **Device configuration** menu item.

The Fronius Smart Meter IP can be operated in single-, two- and three-phase mode. In all cases, the selection is made under the **Components** menu area. The meter type is determined automatically.

A primary meter and several secondary meters can be selected. The primary meter needs to be configured first before a secondary meter can be selected.

The Fronius Smart Meter IP can be connected with Modbus TCP or Modbus RTU.

## Installation using the web browser

### WLAN:

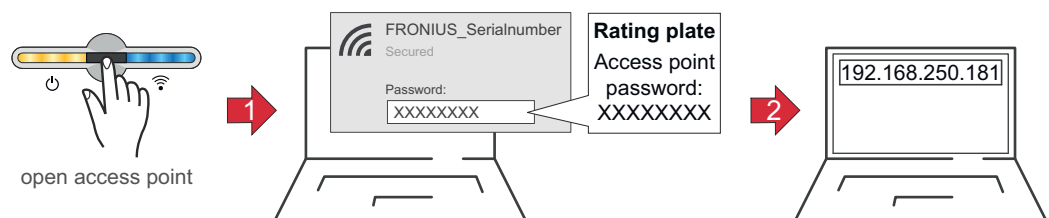

- 1 Open the access point by touching the sensor   
 ✓ *Communication LED flashes blue.*
- 2 Establish the connection to the inverter in the network settings (the inverter is displayed with the name "FRONIUS\_" and the serial number of the device).
- 3 Enter the password from the rating plate and confirm.   
 **IMPORTANT!**   
 To enter the password on a Windows 10 operating system, the link "**Connect using a security key instead**" must first be activated to establish a connection with the password.
- 4 In the browser address bar, enter and confirm the IP address 192.168.250.181. The installation wizard is opened.
- 5 Follow the installation wizard in the individual sections and complete the installation.
- 6 Add the system components in Fronius Solar.web and start up the PV system.

The network wizard and the product setup can be carried out independently of each other. A network connection is required for the Fronius Solar.web installation wizard.

## Ethernet:

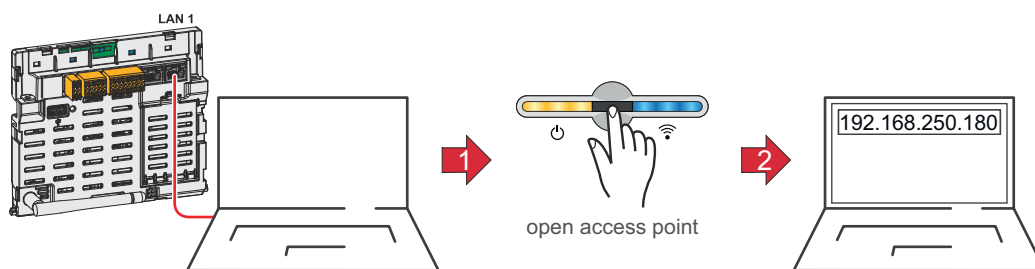

- 1 Establish a connection to the inverter (LAN1) with a network cable (CAT5 STP or higher).
- 2 Open the access point by touching the sensor once   
✓ *Communication LED flashes blue.*
- 3 In the browser address bar, enter IP address 169.254.0.180 and confirm. The installation wizard is opened.
- 4 Follow the installation wizard in the individual sections and complete the installation.
- 5 Add the system components in Fronius Solar.web and start up the PV system.

The network wizard and the product setup can be carried out independently of each other. A network connection is required for the Fronius Solar.web installation wizard.

---

### Configuring the primary meter

- 1 Call up the user interface of the inverter.
  - Open a browser.
  - In the address bar of the browser, enter the IP address (for WLAN: 192.168.250.181, for LAN: 169.254.0.180) or the host and domain name of the inverter and confirm.
  - The user interface of the inverter is displayed.
- 2 Click the **Device configuration** button.
- 3 Log in to the login area with the **Technician** user and the technician password.
- 4 Access the **Components** menu area.
- 5 Click the **Add component** button.
- 6 Select connection type (**Fronius Smart Meter (RTU)** or **Fronius Smart Meter (TCP)**).
- 7 In the **Position** drop-down list, set the position of the meter (**feed-in point** or **consumption point**). For more information on the position of the Fronius Smart Meter IP, see [Positioning](#) on page **12**.
- 8 If using **Fronius Smart Meter (TCP)**, enter the IP address of the Fronius Smart Meter IP. A static IP address is recommended for the Fronius Smart Meter.
- 9 Click the **Add** button.
- 10 Click the **Save** button to save the settings.

The Fronius Smart Meter IP is configured as the primary meter.

---

### Configuring secondary meters

- 1 Establish a connection to the Smart Meter IP (IP WLAN: 192.168.250.181).
- 2 Open a browser.

- 3 Log into the Smart Meter IP user interface and change the Modbus address accordingly under **Advanced settings > Data interface > Modbus address** (1 = primary meter)  
This setting is necessary when using Modbus TCP and RTU.
- 4 Call up the user interface of the inverter.
  - Open a browser.
  - In the address bar of the browser, enter the IP address (IP address for WLAN: 192.168.250.181, IP address for LAN: 169.254.0.180) or the host and domain name of the inverter and confirm.
  - The user interface of the inverter is displayed.
- 5 Click the **Device configuration** button.
- 6 Log in to the login area with the **Technician** user and the technician password.
- 7 Access the **Components** menu area.
- 8 Click the **Add component** button.
- 9 Select connection type (**Fronius Smart Meter (RTU)** or **Fronius Smart Meter (TCP)**).
- 10 In the **Position** drop-down list, select the meter type (producer/load meter).
- 11 Enter the previously assigned address in the **Modbus address** input field. The secondary meter address must match the Modbus address set on the Smart Meter IP.
- 12 Enter the name of the meter in the **Name** input field.
- 13 In the **Category** drop-down list, select the category (**producer** or **load**).
- 14 If using **Fronius Smart Meter (TCP)**, enter the IP address of the Fronius Smart Meter IP under **IP Address**. A static IP address is recommended
- 15 Click the **Add** button.
- 16 Click the **Save** button to save the settings.

The Fronius Smart Meter IP is configured as a secondary meter.

### Modbus participants - Fronius GEN24

**Modbus RTU:** The inputs M0 and M1 can be selected for this purpose. A maximum of 4 Modbus participants each can be connected to the Modbus terminal at inputs M0 and M1.

**Modbus TCP:** A maximum of 7 secondary meters can be used in the system.

#### IMPORTANT!

Only one primary meter, one battery and one Ohmpilot can be connected per inverter. Due to the high data transfer of the battery, the battery occupies 2 participants.

#### Example 1:

Input	Battery	Fronius Ohmpilot	Number of primary meters	Number of secondary meters
Modbus 0 (M0)	✗	✗	0	4
	✓	✗	0	2
	✓	✓	0	1



Input	Battery	Fronius Ohmpilot	Number of primary meters	Number of secondary meters
Modbus 1 (M1)	✗	✗	1	3

Example 2:

Input	Battery	Fronius Ohmpilot	Number of primary meters	Number of secondary meters
Modbus 0 (M0)	✗	✗	1	3
Modbus 1 (M1)	✗	✗	0	4
	✓	✗	0	2
	✓	✓	0	1

**Multi-meter system - Explanation of symbols**



**Grid**

Supplies the loads in the system if insufficient power is being generated by the PV modules or supplied by the battery.



**Inverter in the system**

e.g. Fronius Primo, Fronius Symo, etc.



**Utility meter**

Measures the measurement data relevant for billing amounts of energy (in particular kilowatt hours of energy sourced from the grid and energy fed into the grid). Based on the relevant billing data, the electricity retailer will invoice the energy sourced from the grid and the purchaser of the surplus energy will reimburse the energy fed into the grid.



**Primary meter**

Records the system's load curve and provides measurement data for energy profiling in Fronius Solar.web. The primary meter also controls the dynamic feed-in control.



**Secondary meter**

Records the load curve of individual loads (e.g. washing machine, lamps, TV, heat pump, etc.) in the consumption branch and provides measurement data for energy profiling in Fronius Solar.web.



**Producer meter**

Records the load curve of individual producers (e.g. wind power plant) in the consumption branch and provides measurement data for energy profiling in Fronius Solar.web.



**Modbus RTU secondary device**  
e.g. Fronius Ohmpilot, battery, etc.



**Loads in the system**  
e.g. washing machine, lamps, TV, etc.



**Additional loads in the system**  
e.g. heat pump



**Additional producers in the system**  
e.g. wind power plant



**Terminating resistor**  
R 120 Ohm

### Multi-meter system - Fronius GEN24 inverter

If several Fronius Smart Meters are installed, a separate address must be set for each one (see [Advanced settings](#) on page 48). The primary meter is always assigned address 1. All the other meters are numbered consecutively with the address range from 2 to 14. Different Fronius Smart Meter power categories can be used in combination.

#### IMPORTANT!

Max. 7 secondary meters may be used in the system. A data connection via RTU as well as TCP is possible. To avoid interference, it is recommended to install the terminating resistors according to chapter [Setting the Modbus RTU terminating resistor](#) on page 25.

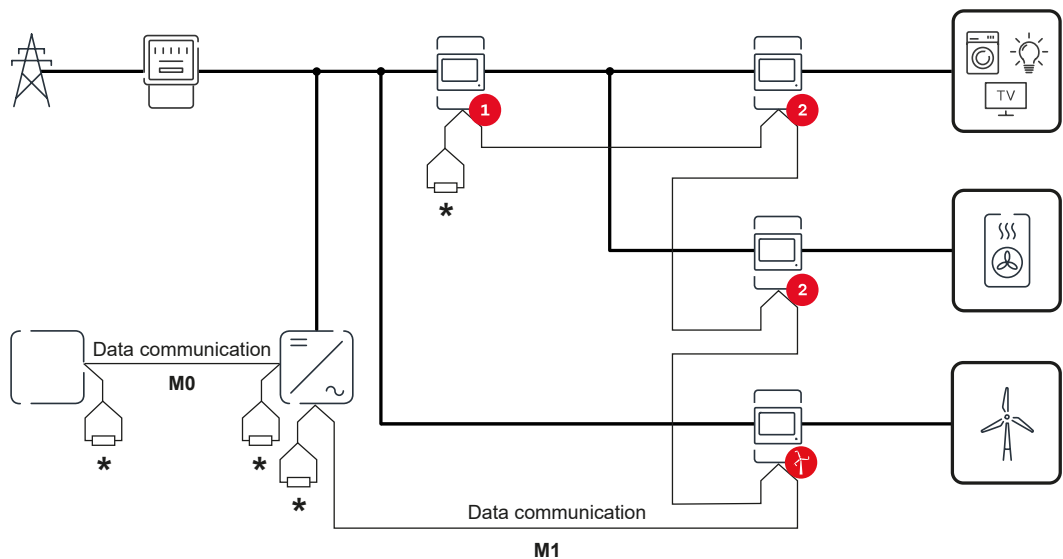

Location of the primary meter in the consumption branch. \*Terminating resistor R 120 Ohm

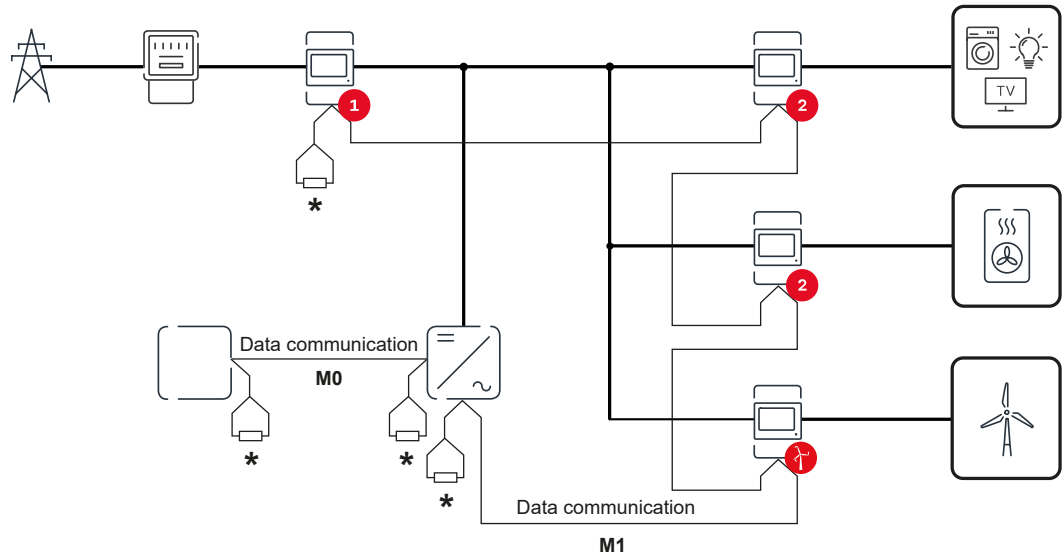

Location of the primary meter at the feed-in point. \*Terminating resistor R 120 Ohm

**The following must be observed in a multi-meter system:**

- Connect the primary meter and the battery to different channels (recommended).
- The remaining Modbus participants must be distributed evenly.
- Only assign each Modbus address once.
- Terminating resistors must be positioned individually for each channel.



# User interface



# Overview

---

## Overview



### Measurement data and connections

An overview of the measurement data (e.g. voltage, amperage, frequency, etc.) and the data communication connections is displayed.



### Language

The desired language can be set here via the drop-down menu.



### Change password

After entering the initial password (123), a new password must be assigned:

#### Password guidelines

- At least 6 characters
- At least 3 of the following 4 properties: Upper case letters, lower case letters, numbers, special characters

If the password has been forgotten, the Smart Meter must be reset (see chapter [Restoring the factory settings](#) on page [49](#)).



### Advanced settings

For more information on the settings, see chapter [Advanced settings](#) on page [48](#).



### Info

Various information about the Fronius Smart Meter IP is displayed here. This information can be helpful in support cases.



### Logout

The current user is logged out.

# Settings

---

## Advanced settings

---

### Network

The WLAN or LAN connection can be configured here. The use of a static IP address is recommended.

---

### Meter values

Here all values can be set to 0 or meter values can be corrected manually.

The input current of the current transformers can be changed, see [Changing the input current of the current transformers](#) on page 49.

---

### Software update

Software update settings can be made here. It is possible to configure an automatic update.

---

### Data interfaces

Several data interfaces can be used simultaneously.

**Detailed views** - Entering the login data is required.

- **Expert view:** All available measured values of the Fronius Smart Meter IP are displayed.
- **REST/JSON:** The current measured data is displayed.
- **REST/XML:** Only visible if the **REST/XML** interface is enabled under **Data interfaces**. The current measured data is displayed.

### Data interfaces

- **REST/XML:** To enable the REST/XML interface.
  - **Fronius Backend:** A connection to a Message Queuing Telemetry Transport (MQTT)-Broker can be set up via the Fronius backend. This setting is required for Fronius EMIL, for example. For further information, please contact your Fronius system partner.
  - **Modbus (TCP and RTU):**
    - **Modbus address:** Must be changed accordingly when multiple meters are in operation (1 = primary meter)
    - **Modbus TCP Port:** This value must match the setting on the inverter (standard port: 502).
- 

### Single-phase/multiphase

The connection type of the Fronius Smart Meter IP can be selected here.

---

### Restart device

Click on **Restart device** to restart the Fronius Smart Meter IP.

---



## Restoring the factory settings

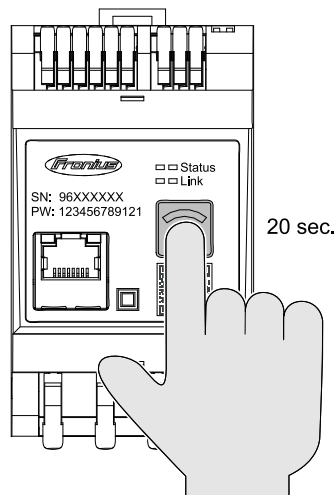

Press and hold the **WLAN access point and reset** button for 20 seconds to reset the Fronius Smart Meter IP to factory settings.

- All LEDs on the Fronius Smart Meter IP go out and the device restarts (can take max. 10 minutes).
- All measured values are set to 0 and the configuration is reset.
- If the factory settings are restored, the device must be reconfigured (see [Commissioning the Fronius Smart Meter IP](#)).

## Changing the input current of the current transformers

The input current of the current transformers can be changed after commissioning:

- 1 Open the menu **Advanced settings > Meter values**.
- 2 Click the **Current transformer** button.
- 3 Enter the input current of the connected current transformers in amperes and click **Next**.  
The input current value is stated in the current transformer user information.
- 4 Confirm the change of the value by clicking on **Save**.



# Appendix



# Care, maintenance and disposal

---

**Maintenance** Maintenance and servicing may only be carried out by Fronius-trained service technicians.

---

**Cleaning** Clean the Fronius Smart Meter as required with a damp cloth. Do not use cleaning agents, abrasives solvents or similar to clean the Smart Meter.

---

**Disposal** Waste electrical and electronic equipment must be collected separately and recycled in an environmentally responsible manner in accordance with the EU Directive and national law. Used equipment must be returned to the distributor or through a local, authorised collection and disposal system. Correct disposal of the used device promotes sustainable recycling of resources and prevents negative effects on health and the environment.

**Packaging materials**

- Collect separately
  - Observe locally valid regulations
  - Compress the cardboard box to reduce volume
- 

**Fronius manufacturer's warranty**

Detailed, country-specific warranty conditions are available at [www.fronius.com/solar/warranty](http://www.fronius.com/solar/warranty).

To obtain the full warranty period for your newly installed Fronius product, please register at [www.solarweb.com](http://www.solarweb.com).

# Technical data

## Technical data

<b>Measuring input</b>	
Nominal voltage (3-phase) including tolerance	208 - 480 V
Nominal voltage (1-phase) including tolerance	100 - 240 V
Self-consumption	30 mA
Nominal frequency Tolerance	50 - 60 Hz 47 - 63 Hz
Maximum current, $I_{max}$	5000 A
Short-time overload (EN IEC 62053-21, EN IEC 62053-23)	$3 \times I_{max} / 20 \text{ s}$
Self-consumption (max. current)	max. 5 W
Current distortion factor	in acc. with EN IEC 62053-21
Power factor Operating range (EN IEC 62053-21, EN IEC 62053-23)	active $\cos\phi$ 0.5 ind - 0.8 cap, reactive $\sin\phi$ 0.5 ind - 0.5 cap
<b>Current transformer (kCT)</b>	1 - 5000 e.g. CT 800/333mV  Do not use Rogowski coils for measurement purposes!

<b>Energy</b>	
Active energy accuracy (EN IEC 62053-21) / Class B (EN IEC 50470-3)	Class 1
Reactive energy accuracy (EN IEC 62053-23)	Class 2
Response time after switch-on (EN IEC 62053-21, EN IEC 62053-23)	< 5 s

<b>Output</b>	
<b>RS485 communication</b> Electrically isolated from input and auxiliary voltage	
Standard	RS485 - 3 conductors
Transmission	Serial, asynchronous
Protocol	Modbus RTU
<b>Addresses</b>	1 - 255
Number of bits	8
Stop bit	1
<b>Parity bit</b>	None - even - odd

<b>Output</b>	
<b>Baud rate</b> (Modbus transmission speed)	9600 bit/s
Response time	≤ 200 ms

<b>WLAN</b>	
Frequency range	2412 - 2472 MHz
Channels used	Channel: 1-13 b,g,n HT20 Channel: 3-9 HT40
Output	<18 dBm
Modulation	802.11b: DSSS (1Mbps DBPSK, 2Mbps DQPSK, 5.5/11Mbps CCK) 802.11g: OFDM (6/9Mbps BPSK, 12/18Mbps QPSK, 24/36Mbps 16-QAM, 48/54Mbps 64-QAM) 802.11n: OFDM (6.5 BPSK, QPSK, 16-QAM, 64-QAM)

<b>Insulation (EN IEC 62052-11, EN IEC 62053-21)</b>	
Installation category	II
Pollution degree	PD2
Insulation voltage	4 kV RMS
Impulse withstand voltage Test circuit	4 kV 1.2/60 μs Voltage input, current transformer input, communication
Test voltage Test circuit	2.5 kV RMS. 50 Hz/1 min Voltage input, current transformer input, communication
Test voltage Test circuit	4 kV RMS. 50 Hz/1 min All circuits and earth

<b>Electromagnetic compatibility</b>	
Test standard	Test in acc. with EN IEC 62052-11

<b>Environmental conditions</b>	
Reference temperature	25 °C (± 5 °C)
Operating range	-25 bis +55 °C
Temperature limit for storage and transport	-30 to +80 °C
Max. humidity	93%
Max. power loss (for thermal dimensioning of the switch cabinet)	≤ 6 W
Overvoltage category	III

<b>Housing</b>	
Housing	3 modules according to DIN 43880

<b>Housing</b>	
Connection	Spring-loaded terminals
Mounting	35 mm DIN rail
Housing material	PA-765 UL
Protection class (EN 60529)	IP20 housing, IP30 connections
Weight	132 grams

<b>Terminals</b>	
<b>Voltage input</b>	
Wire	min. 1.5 mm <sup>2</sup> / max. 4 mm <sup>2</sup>
<b>Data output and current transformer input</b>	
Wire	min. 0.25 mm <sup>2</sup> / max. 2.5 mm <sup>2</sup>











[fronius.com/en/solar-energy/installers-partners/products-solutions/monitoring-digital-tools](https://fronius.com/en/solar-energy/installers-partners/products-solutions/monitoring-digital-tools)

**MONITORING &  
DIGITAL TOOLS**

**Fronius International GmbH**

Froniusstraße 1  
4643 Pettenbach  
Austria  
[contact@fronius.com](mailto:contact@fronius.com)  
[www.fronius.com](http://www.fronius.com)

At [www.fronius.com/contact](http://www.fronius.com/contact) you will find the contact details of all Fronius subsidiaries and Sales & Service Partners.